

The Gainsborough Collection

Wood Burning Free Standing Stoves From Specflue Ltd
CE and EN13240 Approved

Approved for use in Smoke Control Areas when burning dry wood logs



GILCAR >

< DEVONSHIRE



Specflue Ltd

8 Curzon Road, Chilton Industrial Estate, Sudbury, Suffolk, CO10 2XW
T: 0333 999 7974 E: sales@specflue.com

...designed to be better

WOODBURNING STOVES According to the Regulation No 305/2011	CE	Gainsborough Range: Gilcar & Devonshire Models
1. Product type unique identification code	Fireplace Stove For Wood - Requirements and test methods pursuant to EN13240:2002/A2:2005	
2. Product name	Gilcar & Devonshire	
3. Intended use or uses of the construction products in according to the technical specification	Room heater burning wood without water heating	
4. Manufactured and Distributed by	Specflue Ltd, 8 Curzon Road, Chilton Industrial Estate, Sudbury, Suffolk, CO10 2XW www.specflue.com / sales@specflue.com	
5. The systems or systems for the assessment and verification of constancy of construction product performance as set out in annex V	System 3	
6. Notified body relevant to the assessment and verification of performance	Strojirensky Zkusebni Ustav S.P. Notified No NB1015	
7. Declaration of Performance	Gilcar	Devonshire
Harmonised technical specification Emissions tested to EN16510 @ Nom output and 13% O2	EN13240:2002/A2:2005	
CO%	0.07	0.08
Flue gas flow rate	4.7	5
Nox (mg/Nm ³)	132	127
OGC (mg/Nm ³)	90	37
Dust	36	31
8. Fire Safety	Gilcar	Devonshire
Reaction to fire	A	A
Test of fire safety in connection with burning of wood	Pass	Pass
Distance to combustibles		
Rear (mm)	100	100
Sides (mm)	200	275
Front (mm)	400	400
9. Safety	Not tested	
Mechanical strength to support a chimney	NPD	
Electrical	Pass	
Surface temperature	Pass	
Cleanability	Pass	
10. Thermal output	Gilcar	Devonshire
Nominal Heat Output kW	4.5	4.9
Energy Efficiency %	80.7	80.5
Flue gas temperature deg C	243	285
Water heating	N/A	N/A

The performance for the products identified in point 2 is in conformity with the declared performance in point 7. This declaration of performance has been issued under the sole responsibility of the manufacturer as identified in point 4 above.

Signed on behalf of the manufacturer:



Jeremy Fry, Chairman - 15.04.19

Congratulations on the purchase of your new stove! Your new purchase will provide you with a level of pleasure and comfort not previously experienced in your home.

The Gainsborough collection of stoves are a heavy duty British designed wood burning stove. They have been designed for easy installation and ease of use giving a lovely flame pattern when burning wood and a wonderful warm radiant and convection heat. The stoves are highly efficient with a clean burn firebox and efficiencies above 80% (Net) when burning wood and feature a curved door, large glass window, vermiculite insulated firebox, convector top plate, bolt on adjustable feet, ergonomic handle and heavy weight steel construction.

Please read and follow the advice and instructions on the safe and efficient operation of your stove to ensure it has a long trouble free life and also read and follow the installation instructions before installing the stove.

OPERATING INSTRUCTIONS

A wood burning stove is a very efficient heating appliance and must be installed and used safely and wisely. It is important to understand the working of such an appliance and to understand the process of converting the fuel into heat and its efficient transfer from the firebox to the room in order to gain the most from the stove.

A stove creates an almost perfect environment to burn wood in. The firebox will run at a very high temperature ideal to burn the volatiles given off in the burning process and the precise air controls allow minimal heat loss into the flue. These stoves operate at an efficiency of approx 73.2% Gross CV basis (+80.5% Net) and are very much more efficient than an open fire avoiding the wasteful draughts normally associated with that type of appliance.

Burning wood is the natural way to store the sun's energy to then be released in a carbon neutral process to heat your house when the need is most. On a cold winter's night there is nothing to beat the release of heat and flame in a stove to raise the spirits.

The preparation and burning of wood as a fuel in stoves can be traced back many centuries, however it is a forgotten or maybe never fully discovered activity in the United Kingdom, we have much to learn from our European and Scandinavian neighbours whose colder winters have instinctively led them into a natural wood burning culture.

Wood for fuel is probably one of the most environmentally friendly energy sources. It is carbon neutral; trees used for fuel production regenerate very quickly and it is a pleasant and satisfying job preparing the firewood for the coming winters.

WARNING NOTE

Properly installed, operated and maintained this stove will not emit fumes into the dwelling. Occasional fumes from de-ashing and refueling may occur. However, persistent fume emission is potentially dangerous and must not be tolerated. If fume emission persists, then the following immediate action should be taken:

- a) Evacuate the property immediately.
- b) Open doors and windows to ventilate room as you leave the premises.
- c) Let the fire go out.
- d) Open the doors and windows in your property and ventilate thoroughly.
- e) **Do not attempt to relight the fire** until the cause of the fume emission has been identified and corrected. Seek expert advice e.g. HETAS approved installer/ chimney sweep.
- f) If you feel unwell, go to the doctors, call NHS direct on 111 or if urgent call 999 for an ambulance – tell them your symptom may be relating to carbon monoxide poisoning.

The most common cause of fume emission is flue or chimney blockage. For your own safety these must be kept clean at all times. Any permanent air vent provided for combustion air must not be blocked off. Care must be taken if an extractor fan is fitted in the same room as the stove as this can cause the stove to emit dangerous fumes into the room. Your installer should have fitted an approved CO alarm in the same room as the appliance. If the alarm sounds unexpectedly then follow procedures shown above.

CHIMNEY CLEANING

The chimney should be swept a minimum of twice a year for wood burning appliances. It is important that the flue connection and chimney are swept prior to lighting up after a prolonged shutdown period. If the stove is fitted in place of an open fire then the chimney should be swept one month after installation to clear any soot falls which may have occurred due to the difference in combustion between the stove and the open fire.

In situations where it is not possible to sweep through the stove the installer will have provided alternative means such as a soot door. After sweeping the chimney, the stove flue outlet and the flue pipe connecting the stove to the chimney must be cleaned with a flue brush. Please ensure you use a registered / Approved Chimney Sweep, who will provide you with a certificate for this work.

It is possible to sweep through these stoves by removing the lower vermiculite baffle and upper steel baffle to gain access to the flue pipe. The method of removal is described later in the manual.

The connecting flue pipe and stove baffle should be checked monthly to clear any fly ash or soot deposits.

USE OF A FIREGUARD

When using the stove in situations where children, aged and/or infirm persons are present a fireguard must be used to prevent accidental contact with the stove. The fireguard should be manufactured in accordance with BS 8423:2002.

INSTRUCTIONS FOR USE:

First Firing

The stove has been treated with a heat-resistant coating, which hardens at a temperature of approximately 250 °C. This hardening process causes the production of smoke and malodorous fumes, so the room must be very well ventilated.

During the first firing, which should be carried out using approximately 1 kg of wood, the door must be left slightly open and must not be closed until the stove is cold. This is to prevent the sealing rope sticking to the stove. It is important not to overheat during this first firing; a stove pipe thermometer can indicate the flue gas temperature.

RECOMMENDED FUELS

The recommended fuel that can be burnt on these stoves is wood logs (Woodsure approved – Ready to Burn).

Correct firing provides optimal heat output and maximum economy. At the same time, correct firing prevents environmental damage in the form of smoke and malodorous fumes and also reduces the risk of chimney fires.

Well seasoned woodfuel is essential for correct use. Make sure your fuel is kept dry. If the fuel is wet, a large proportion of the heat will be used to vaporize the water, and this energy will disappear up the chimney. It is clearly not only uneconomical to fire with wet fuel but also, as mentioned above, increases the risk of producing soot, smoke and other environmentally damaging by-products. When wood is used as a fuel, it is important that it is dry, i.e. wood with moisture content less than 20% - this can be identified through the use of a moisture meter. Ideally firewood needs seasoning for at least 2 summers, logs should be stacked in a well ventilated situation, and logs over 100mm diameter should be split. The stack should be protected from rain but remain well ventilated.

Generally dry wood (<20% moisture content) produces 4.5kW/h per kg; semi dry about 3kW/h per kg and wet wood 1kW/h per kg demonstrating that fewer drier logs are required to produce the same amount of heat output.

Appliance	Wood Length
Gilcar	26cm
Devonshire	36cm

FUEL CONSUMPTION AT NOMINAL HEAT OUTPUT

Appliance	Nominal Output kW	Wood kg/hr
Gilcar	4.5	1.35
Devonshire	4.9	1.66

Tested according to the requirements of EN13240. Note that different fuel consumption results may be achieved due to other factors which include the fuel, chimney draught and atmospheric conditions etc.

The nominal output is the output to which the stove has been tested. In practice, the stove burns with a heat output range between its minimum and maximum ratings.

LIGHTING AND COMBUSTION

A single lever air control located underneath the bottom of the door controls the air that enters into the stove through the rear air inlet. The combustion air flows up the back of the stove preheating before flowing the glass window as secondary air. This secondary air creates an “air-wash” to keep the glass clean and feeding the fire; it is this secondary combustion that completes the burning cycle by turning unburnt volatiles into flame. Finally, any remaining un-burnt volatiles, hydrocarbons and particulates are burnt when preheated tertiary air enters the firebox through the tertiary air diffuser at the rear of the firebox. In practice, normal running will be with the air lever in the mid-point position.

As much as half of the heat obtainable from wood is achieved from secondary and tertiary combustion. It is important that the firebox temperature is maintained at a high level as this also aids complete combustion. For example, when first lighting a stove it is important to get it really hot before closing the burning rate down. The firebox temperature should reach 400°C which equates to approximately 250 °C at the flue pipe.

These stoves are designed and fully tested to burn extremely cleanly with very little smoke discharge and are exempt for use in smoke control areas throughout the UK when burning dry wood logs. To comply, a built-in permanent stop is fitted as standard to the air control mechanism so that it cannot be closed completely (Gilcar 15% open; Devonshire 10% open) and will always allow air to enter. A permanent amount of primary air must therefore enter the firebox to feed the fire producing negligible amounts of smoke and unburnt hydrocarbons. See Appendix A of this manual for further details.



1. Put 2 small logs on a bed of ash spaced about 6-7cm apart. Place 1-2 firelighters in between and move air lever to right (fully open)



2. Neatly stack dry kindling on top of the logs in a # formation of approx 3 layers and light the bottom fire lighters



3. With the door slightly open the fire will quickly build, warming the stove and chimney. Once the flames are established the door can be shut and the stove can be controlled by the air slider. Adjust the air lever to the left to find the optimal combustion



4. After about 35/45 minutes, when the last flames have gone out a red hot ember bed will be left and further wood can be added



5. Place 2/3 logs on the hot embers and ensure that the wood is not stacked too closely with the air slider fully open. The wood will ignite in 2/3 minutes. Adjust the air slider for optimum combustion

Note:

If the fire dies down completely or embers are smoldering then it will be necessary to place some firelighters onto the grate with some kindling or small pieces of wood to reestablish the fire once again. Leave the air slider fully open and allow the fire to build before refueling with larger pieces of wood and then adjust the air slider for optimum combustion.

Refuelling onto a low fire bed: If there is insufficient burning material in the firebed to light a new fuel charge, excessive smoke emission can occur. Refuelling must be carried out onto a sufficient quantity of glowing embers and ash that the new fuel charge will ignite within a reasonable period. If there are too few embers in the fire bed, add suitable kindling to prevent excessive smoke.

Do not overload the firebox by loading above the tertiary air diffuser at the back of the firebox and ensure that the wood is retained by the log guard. Always ensure that the wood is not tightly stacked so that air can circulate freely.

Do not leave the door open: Operation with the door open can cause excess smoke. The appliance must not be operated with the appliance door left open except as directed in the instructions.

Do not leave the air sliders completely open: Operation with the air slider permanently open can cause excess smoke. The appliance must not be operated with air controls or dampers left open except as directed in the instructions.

SLUMBERING A STOVE

Whilst it may seem appealing, slumbering a stove at the end of an evening is not to be recommended. Not only is this harmful to the environment due to the incomplete combustion of the fuel but there is a potential to create longer term problems to the stove internal components which also includes the glass door panel and flue components. Incomplete combustion of the fuel will lead to gas build up in the fire chamber potentially including Sulphur, which under certain conditions can start attacking these components. This practice WILL void all warranties.

SAFETY PRECAUTIONS

A risk of blowback and/or explosion can arise if too much dry wood is placed in the stove and burnt with insufficient combustion air. This may result in the production of gaseous compounds which can ignite if the intake of primary and secondary air is insufficient and the firebox temperature too low.

For wood burning it is an advantage always to leave some ash lying in the bottom of the combustion chamber. Take care when emptying the ash pan, as cinders can continue to burn in the ash for long periods of time.

MAINTENANCE OF MATT BLACK PAINT FINISH

The surface of the stove has been treated with heat-resistant paint. The stove can be cleaned with a soft brush after it has cooled down. Any damage to the surface in the form of chips or scratches can be repaired using touch-up paint, which is available in spray cans. If the stove has become grey in colour due to overheating, touch-up paint of this kind can be used to repaint the stove entirely. Alternatively the stove can be maintained with a traditional type of stove polish of which there are several proprietary makes available. Do not use an aerosol spray anywhere near the stove when it is either alight or still hot – allow it to cool down before respraying.

MAINTENANCE OF THE STOVE GLASS

Incorrect firing, for example using wet wood, or slow burning can result in the viewing window becoming covered in soot. This soot can be easily and effectively removed by using a dry wiper glass cleaner, when the glass is cold. Burning contaminated, incorrect solid fuels or fuels high in Sulphur may cause permanent damage to the glass, which is not covered by any warranty.

OPERATIONAL PROBLEMS

In the event of smoke or malodorous fumes being produced, you must first check to see whether the chimney is blocked. The chimney must, of course, always provide the minimum draught necessary (12 Pa) to ensure that it is possible to regulate the fire. However, the chimney draught may also be affected by weather conditions. Both wind and temperature can affect the performance of a chimney.

In cases where the wood burns too quickly, this may be due to excessive chimney draught. You should also check to make sure that the door seal is intact. If the stove produces too little heat, this may be due to the fact that you are firing with wet wood. A large proportion of the heat output will be used to dry the wood, resulting in both uneconomical heating and an increased risk of soot and tar deposits forming in the chimney.

STANDING DOWN AT THE END OF THE SEASON

At the end of the burning season the stove should be prepared for the stand down period, this is to prevent corrosion both in the stove and flue system.

The stove should be cleared of all ash, the baffle and flue ways cleared of soot and fly ash and the chimney swept.

All air vents should be in the open position and it is recommended that the door is left ajar to ventilate the chimney.

This is the ideal time to check for parts that may need replacing and to lubricate door hinges and catches. Also it is recommended that all screws holding the glass in place are removed and replaced with a high temperature lubricant such

as copper slip.

INSTALLATION INSTRUCTIONS

(for UK excluding Scotland where local Building regulations must be conformed to).

It is essential that the installation is carried out by an experienced and competent installer, ideally HETAS registered (see www.hetas.co.uk) and with reference to BS 8303, Code of Practice for installation of domestic heating and cooking appliances burning solid mineral fuel. Under England & Wales Building Regulations it is a legal requirement that the stove is either installed by a competent person, or that the installation is carried out under Local authority building control approval. Your HETAS installer should install and test all parts of the stove and flue before providing certification for the property.

CO ALARMS

Building regulations require that whenever a new or replacement fixed solid fuel or wood/biomass appliance is installed in a dwelling a carbon monoxide alarm (to BS EN 50291-1:2018) must be fitted in the same room as the appliance. Further guidance on the installation of the carbon monoxide alarm is available in BS EN 50292:2002 and from the alarm manufacturer's instructions. Provision of an alarm must not be considered a substitute for either installing the appliance correctly or ensuring regular servicing and maintenance of the appliance and chimney system. CO alarms should be regularly tested and kept free from dust and debris with regular vacuuming.

HEALTH AND SAFETY PRECAUTIONS

Special care must be taken when installing the stove such that the requirements of the Health and Safety at Work Act are met.

Manual Handling

Adequate facilities must be available for loading, unloading and site handling.

Fire Cement

Some types of fire cement are caustic and should not be allowed to come into contact with the skin. In cases of contact, wash immediately with plenty of water and refer to COSHH data sheets.

Asbestos

This stove contains no asbestos. If there is a possibility of disturbing any asbestos in the course of the installation then please seek specialist guidance and use appropriate protective equipment.

Metal Parts

When installing or servicing this stove care should be taken to avoid the possibility of personal injury.

ASSESSING THE REQUIREMENTS FOR THE INSTALLATION OF A STOVE

Your supplier or HETAS registered installer will be able to advise you on the individual requirements that are needed to install a stove safely.

It is most important that the stove is the correct size. This means that the output should match the heat requirements of the room. Also to be considered is the fuel choice and the provision of suitable and convenient storage with easy access to the stove.

Having decided on the ideal appliance then the installation should be fully assessed. The chimney requirements should be carefully assessed. Hearth requirements should be carefully specified, remember the building regulations lay out the minimum requirements. The chances of damaging a floor or carpet will be much reduced if the depth of a hearth is extended beyond the minimum. Any combustible materials should be at least 500mm distance from the sides and back and 800mm clear of the door and should never be allowed to exceed 80 °C. For further advice on chimney and hearth also see details below.

Assess also the fireplace surround if any is to be used, it is essential that combustible materials are not used close to the stove and flue pipe. This requirement may vary depending on the shielding but is advised to keep combustible materials at least 500mm or preferably 1 metre away from the stove or flue pipe.

THE FOLLOWING ITEMS ARE INCLUDED WITH THE STOVE

A pair of leather gloves for operation of door handle and refueling the stove, an ash pan and handle.

HEARTH

The fireplace and hearth should conform to at least the minimum requirements laid out in the Building Regulations Approved Document J. The hearth should be able to accommodate the weight of the stove and its chimney if the chimney is not independently supported.

Stoves must stand on a non-combustible hearth that must extend at least 300mm in front and 150mm to both side and rear if the flue outlet is from the top.

DIMENSIONS AND CLEARANCES

No Combustible materials should be used in the construction of a fireplace or within the chimney or used in the installation of a stove, flue or chimney.

Care should also be taken in the construction of hearths or fireplaces to ensure that suitable provision is taken to allow for expansion and contraction of the construction materials.

When installing these stoves in a fireplace recess, sufficient space must be provided on either side, behind and above to allow for heat convection and for access for maintenance of stove, flue pipe and chimney:

Minimum clearances in a solid masonry fireplace recess:

	Sides	Rear	Top
Gilcar & Devonshire	50mm	50mm	150mm

Minimum clearances from non solid masonry in a freestanding situation:

	Sides	Rear	Top
Gilcar	200mm	100mm	200mm
Devonshire	275mm	100mm	250mm

* Recommended minimum clearance to combustible materials 800mm from the front, and 150mm from the rear.

Any combustible materials in the vicinity of an appliance, whether exposed or covered, should be protected to ensure that the surface temperature does not exceed 65°C plus ambient room temperature (approx 86°C). The installer is responsible for ensuring the correct materials and distances are used and maintained.

It is deemed safe to install these stoves on a combustible floor provided it is covered by a non-combustible hearth plate of at least 12mm thickness and extends at least 300mm in front and 150mm to either side.

Note: un-insulated flue pipe must be installed to local building regulations and flue manufacturer's installation instructions.

BAFFLE PLATE REMOVAL

These stoves are fitted with a twin baffle system to improve efficiency and lower CO with the lower one made from vermiculite and the upper one made from steel. Removal of the steel baffle allows immediate access into the flue system for sweeping.

Removal of lower vermiculite baffle:



1. Remove the front base brick part



2. Gently lift the front fence up and out of the stove followed by the grate and remaining base bricks



3. Ease the right hand side brick away whilst supporting the front baffle section with your other hand. Carefully manoeuvre both baffle brick sections out of the stove



4. Remove the left hand side brick followed by the 2 rear bricks

Removal of upper steel baffle:



1. The upper steel baffle sits in a bolt-up housing at the top of the inside of the stove



2. Removal is a simple process of pushing the top of the plate up which lifts the pegs clear of the housing



3. Twist the steel baffle as the pegs disengage from the housing to remove



4. Removal of the baffle gives immediate access to the flue for sweeping and maintenance.

CHIMNEY IMPORTANT WARNING

This stove must not be installed into a chimney that serves any other heating appliance. The chimney must be a minimum height of 4.5 metres overall height and be in accordance with Building Regulations Approved Document J and reference should be made to British Standard BS EN 15287-1:2007 design, installation and commissioning of chimneys. Any chimney, either masonry or a prefabricated stainless steel system must be constructed and installed according to building regulations. It is recommended that the minimum diameter of the flue liner be 150mm. For new masonry chimneys we recommend pumice cement liners. A chimney draught of at least .06" (12Pa) is recommended. If it is found that there is excessive draught in the chimney then a draught stabiliser should be fitted (check ventilation requirements). Provision must be made for easy sweeping of the chimney. A soot door can be built into a masonry chimney and flue pipe is available with cleaning doors.

Any bend in the chimney or connecting fluepipe should not exceed 45°.

THE CHIMNEY CONNECTION

The flue pipe for connecting the appliance to the chimney must be installed according to Building Regulations Approved Document J and its diameter must be not less than the diameter of the outlet of the appliance. The flue pipe must be adequately sealed to both the stove and the chimney to avoid any leakage.

ALL CHIMNEYS SHOULD BE SWEEPED AND INSPECTED BEFORE INSTALLATION OF ANY APPLIANCE

For relining existing chimneys, 316 or 904 grade stainless steel liners or pumice cement liners in accordance with Building Regulations Approved Document J should be used. Liners should be suitably insulated. Any chimney relining must be carried out by an experienced and competent installer who is HETAS registered (see www.hetas.co.uk). The HETAS Guide to Approved Products and Services lists Chimneys and lining systems suitable for use with solid fuel.

The installer must make allowance for sufficient expansion gap in appliance spigot when connecting to a suitable flue pipe/ chimney system

SWEEPING THROUGH STOVES

When installed with a top flue outlet it is possible to power/ rotary sweep through these Stoves. Remove the baffles as described previously, and access can be gained to the flue pipe.

VENTILATION

Permanent ventilation may be required in accordance with the guidelines given in Approved Document J of The Building Regulations. For houses built before 2008, purpose made ventilation is not required on these stoves. Houses built after 2008 where the air leakage rate is less than 5m³/hour/m² then a ventilator equivalent to 550mm² per kW output will be required (4kW x 550mm² = 2200mm²). The person carrying out commissioning should always carried out smoke tests / spillage tests / re-fueling tests / de-pressurisation test to verify that the stove has met the air supply demand.

COMMISSIONING

The installer should carry out the following checks and ensure that the stove is fully functional. We strongly recommend that a first firing is included in the commissioning process:

1. Check all flue pipe connections
2. Check door latch mechanism
3. Check door and glass seals are all intact and secure
4. Warm chimney and check draught
5. Instruct customer in use of stove
6. Leave instructions for customer
7. Check that after initial firing the door seals are not stuck to the body of the stove

WARRANTY

The stove range is automatically covered by a 12 month warranty for safety, performance and construction. Under the Terms and Conditions, the installation of the stove will need to both comply with the current building regulations and be installed by a qualified HETAS engineer. Furthermore, the stove has to be serviced and maintained annually by a suitably qualified HETAS or chimney engineer and the certificate of installation and all records/receipts and annual servicing records will need to be provided in the event of any claim.

Please note, as is normal practice in the industry, bricks, baffles, glass, grate, log retaining fence, ash pan and rope seals are considered wearing parts requiring replacement during routine maintenance and as such are not covered under any warranty conditions.

Spare parts can be ordered through the stockist who supplied the stove or directly through Specflue Ltd.

In the event of any warranty claim then in the first instance a claim must be made with the stockist or stove dealer who supplied the stove and must follow our Terms and Conditions as set out below. It is entirely at Specflue Ltd decision whether to repair or replace any part that it considers are defective. Any repaired or replaced parts are covered only for the remaining warranty period of the stove unit.

TERMS AND CONDITIONS

Your Gilcar / Devonshire stove is guaranteed against any defects providing:

1. The stove was installed according to our instructions and installation was carried out by a qualified HETAS or an appropriate Building Control Certificate of Completion was issued which must accompany any claim
2. No damage has occurred during the installation
3. The chimney has either been inspected and repaired as necessary or replaced with a suitable flue system and any high draught issues have been remedied
4. The serial number of the stove must accompany the claim
5. The stove must be kept in a continuous serviceable condition with no corrosion evident or allowed to have taken place. If older than 12 months then proof of an annual service record must be provided.
6. There has been no modifications made to the construction or internal components or incorrect service parts installed
7. The stove has not been over-fired through:
 - a. Overfilling the firebox with fuel and/or burning it continuously with fully open air sliders
 - b. Burning incorrect or prohibited fuels e.g., house coal, fuels containing high levels of petroleum coke, sulphur, wet or contaminated wood (paint, varnish, creosotes etc)
8. Excessive ash when burning wood has been removed
9. The stove has not been allowed to slumber continuously overnight
10. The stove is not used in a damp environment
11. The stove has not been used in a commercial environment (rental property, hotel, public barn etc.) where there is opportunity for the members of the public who are not familiar to the operation to misuse or abuse the safe operation of it

LIMITATION OF WARRANTY

The warranty is not transferrable and will only stay with the original retail purchaser. Copy of the original sales receipt will need to be seen as proof of purchase. It does not cover such things as unauthorised modifications or repairs, misuse or abuse, accidental damage, illegal installations and if the stove has not been serviced every 12 months.

Specflue Ltd will not under any circumstances cover any incidental or consequential loss which includes any commercial loss, damage to any furnishings, damage to non-related products, removal/reinstallation costs, transports delay or additional transport costs or any injury to persons or property.

The Specflue Ltd warranty does not affect your statutory rights.

APPENDIX A

The Clean Air Act 1993 and Smoke Control Areas

Under the Clean Air Act local authorities may declare the whole or part of the district of the authority to be a smoke control area. It is an offence to emit smoke from a chimney of a building, from a furnace or from any fixed boiler if located in a designated smoke control area. It is also an offence to acquire an “unauthorised fuel” for use within a smoke control area unless it is used in an “exempt” appliance (“exempted” from the controls which generally apply in the smoke control area).

In England appliances are exempted by publication on a list by The Secretary of State for Environment, Food and Rural Affairs in accordance with the changes made to section 20 and 21 of the clean air act 1993 by section 15 of the deregulation act 2015.

Similarly in Scotland appliances are exempted by publication on a list by Scottish Minister under section 50 of the Regulatory Reform (Scotland) Act 2014.

In Wales and Northern Ireland these are authorized by regulations made by Welsh Minister and by the Department of the Environment respectively.

The Gilcar and Devonshire stoves have been recommended as suitable for use in smoke control areas when burning wood logs.

Further information on the requirements of the Clean Air Act can be found here: <https://www.gov.uk/smoke-control-area-rules>

Your local authority is responsible for implementing the Clean Air Act 1993 including designation and supervision of smoke control areas and you can contact them for details of Clean Air Act requirements.

The Gilcar is fitted, as standard, with a mechanical stop to prevent closure of the secondary air controls beyond 15% open.

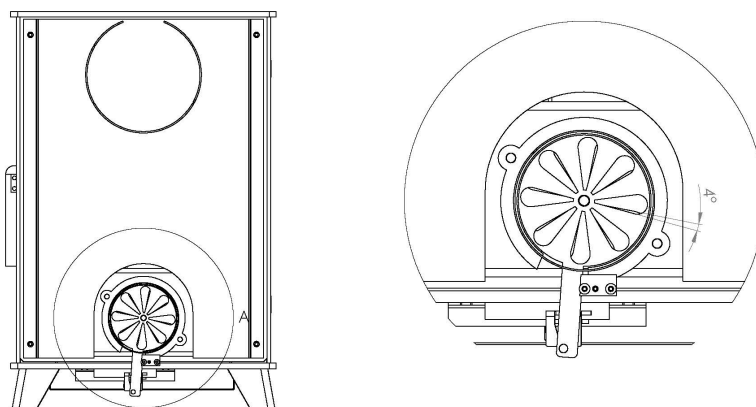

The Devonshire is fitted, as standard, with a mechanical stop to prevent closure of the secondary air control beyond 10% open.

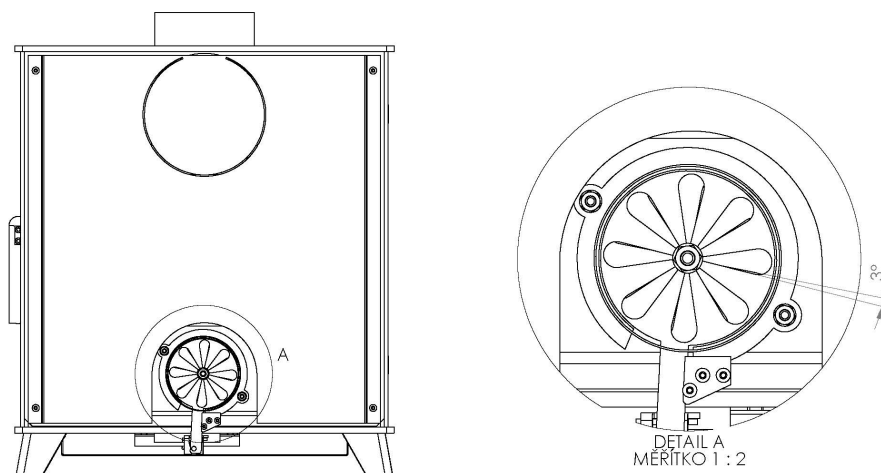

APPENDIX B

Technical Specifications for Gilcar & Devonshire Fresh Air Models

GILCAR

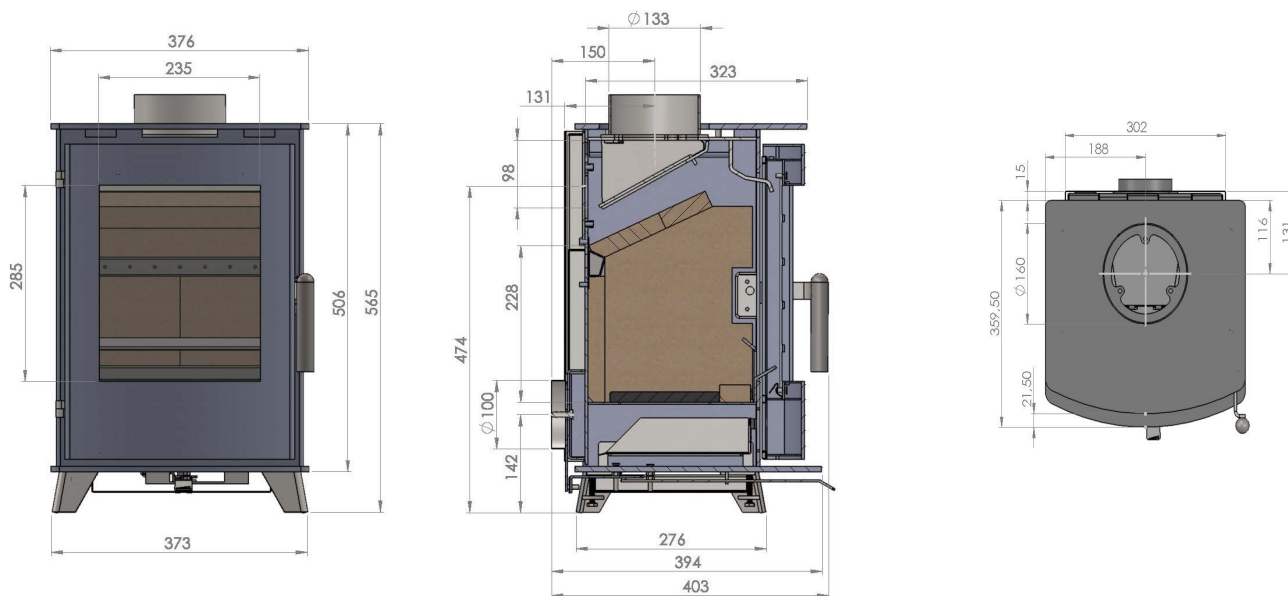

DEVONSHIRE

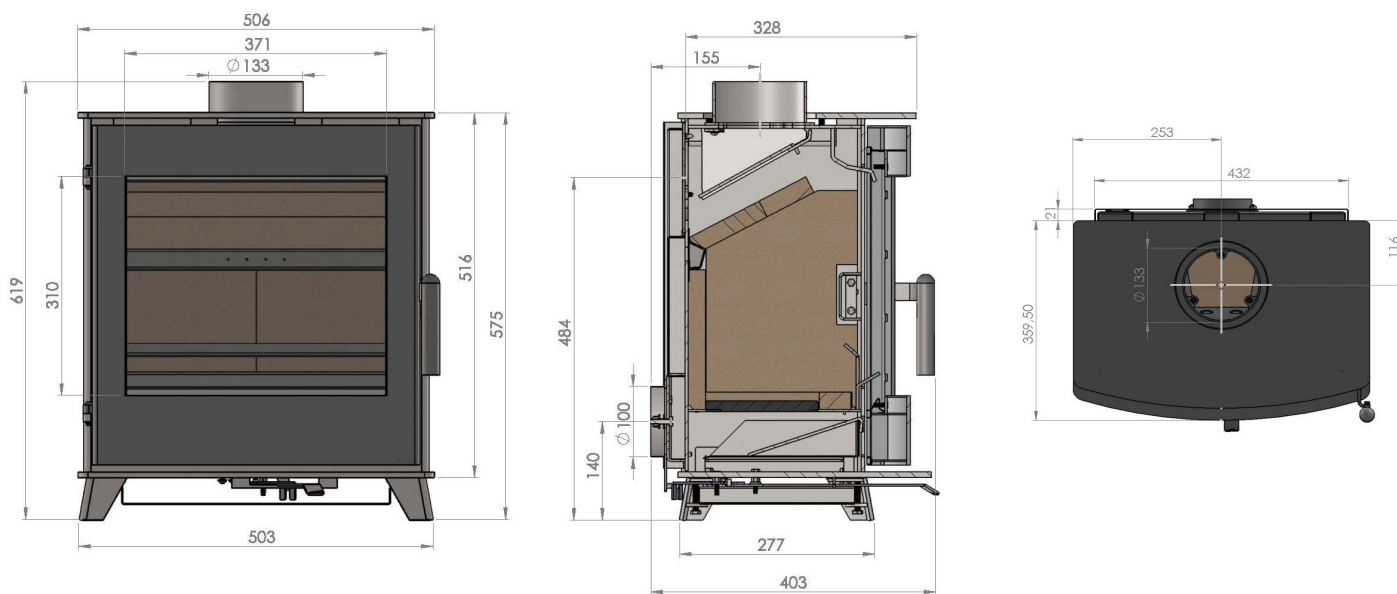

	Gilcar	Devonshire
Width x max depth x height (mm)	376 x 394 x 565	506 x 403 x 575
Weight (kg)	85	95
Maximum log length (mm)	260	360
Top/ Rear flue diameter (mm)	128	128
Nominal output (kw)	4.5	4.9
Distance from rear of stove to centre of top flue outlet (mm)	140	140
Distance from floor to centre of rear flue outlet (mm)	480	490
Efficiency (Net): Wood %	80.72	80.5
Energy efficiency label	A+	A+
CO% @ 13% O ₂ : Wood	0.07%	0.08%