

OPERATION AND INSTRUCTION MANUAL

Balanced Flue Gas Stoves

Ashcott, Ashcott with logstore

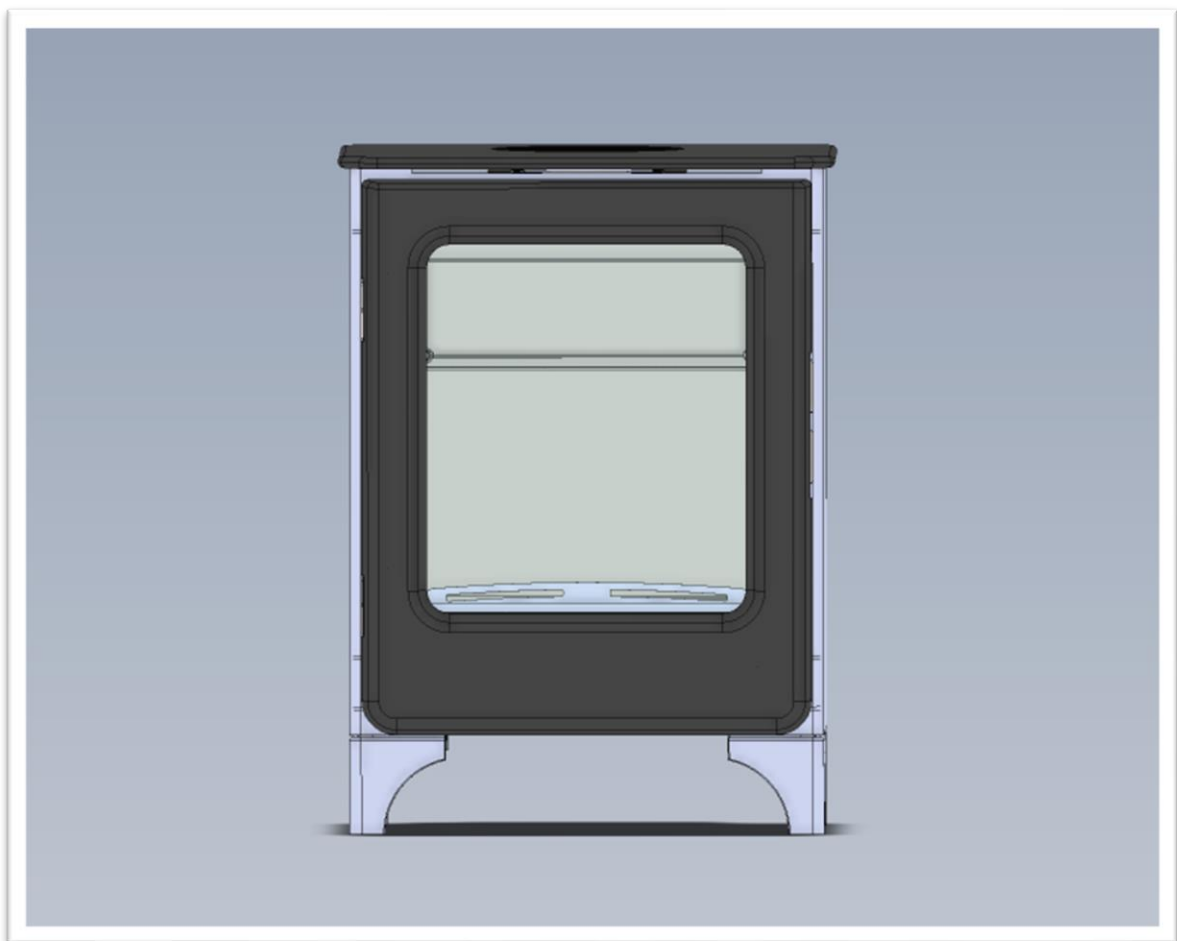

INSTALLATION, SERVICING AND USER INSTRUCTIONS

For use in GB & IE (United Kingdom and Ireland)

This appliance has been tested and certified for other counties (see technical data). However to install appliance in other countries, modification of the appliance and its method of installation may be necessary in order to use the appliance safely and correctly. The manual for the local language must be obtained. Contact Mendip for further information.

This product has been tested, and certified for use on Biopropane Gas. Biopropane Gas can be used as a fuel, with no adjustment necessary if the product is installed as an LPG version.

This Manual covers the following Products: Ashcott, Ashcott with Logstore

Mendip stoves Warranty

Each Mendip stove is designed and built with great care, using quality materials. Ensuring the quality of our product is an integral part of the production process. Your stove comes with a 1 year warranty on manufacturing defects; this can be extended to 5 years against manufacturing defects if your stove is purchased through a registered Mendip Stoves retailer and installed by a qualified GAS SAFE installer. The 5 year extended warranty will only apply if we have received the completed registration card within 1 calendar month of the purchase of your appliance.

Register online today to activate warranty: www.mendipstoves.co.uk/SIT/StoveRegistration

Please see the Warranty Card for the complete terms and conditions.

HEALTH AND SAFETY PRECAUTIONS INFORMATION FOR THE USER, INSTALLER AND SERVICE ENGINEER

Special care must be taken when installing a stove such that the requirements of the Health & Safety at Work Act are met.

Handling

Adequate facilities must be available for loading, unloading and site handling.

Fire Cement

Some types of fire cement are caustic and should not be allowed to come into contact with the skin. In case of contact wash immediately with plenty of water.

PREPARATORY WORK AND SAFETY CHECKS

IMPORTANT WARNING

This stove must not be installed into a chimney that serves any other heating appliance. There must not be an extractor fan fitted in the same room as the stove because this can cause the stove to emit fumes into the room.

Asbestos

This stove contains no asbestos. If there is a possibility of disturbing any asbestos in the course of installation, then please seek specialist guidance and use appropriate protective equipment.

Metal Parts

When installing or servicing this stove care should be taken to avoid the possibility of personal injury.

CO Alarms:-

Building regulations require that whenever a new or replacement fixed solid fuel or wood/biomass appliance is installed in a dwelling a carbon monoxide alarm must be fitted in the same room as the appliance. Further guidance on the installation of the carbon monoxide alarm is available in BS EN 50292:2002 and from the alarm manufacturer's instructions.

Provision of an alarm must not be considered a substitute for either installing the appliance correctly or ensuring regular servicing and maintenance of the appliance and chimney system.

Stove paint Aerosols

Paint aerosols are flammable and therefore dangerous to use around a lit stove. Be sure to allow aerosols spray paints to dry and ventilate the room well before lighting the stove. The use of any aerosol around lit stove is dangerous and care must be taken in handling aerosols.

Content

1. General Notes	4
2. User instructions.	5
2.1 <i>Emergency Gas Isolation</i>	5
2.2 <i>First Time of Operation</i>	5
2.3 <i>Control Overview</i>	6
2.3.1 <i>Basic Manual Control</i>	6
2.3.2 <i>Remote Control</i>	8
2.4 <i>Manual Turn OFF</i>	14
2.5 <i>Cleaning and Maintenance</i>	14
3. Installation instructions.	15
3.1 <i>Gas Connection</i>	15
3.2 <i>Ventilation</i>	15
3.3 <i>Appliance Fireplace Installation</i>	15
3.4 <i>Flue Connection</i>	16
3.5 <i>Fuel Bed Arrangements</i>	32
3.6 <i>Commissioning the appliance</i>	36
4. Servicing	37
4.1 <i>Cleaning the Ceramics</i>	37
4.2 <i>Servicing the Burners</i>	37
4.3 <i>Spare parts</i>	38
5. Technical Information	39
5.1 <i>Countries of Use</i>	39
5.2 <i>Technical Data</i>	40
5.3 <i>Dimensions</i>	41

IMPORTANT SAFETY INFORMATION

▲ WARNING

Fire or explosion hazard. Read these instructions carefully. Failure to follow them could result in a fire or explosion causing property damage, personal injury, or loss of life. The product must be installed and operated according to all codes and local regulations.

Damper position must be in accordance with Manufacturer's Installation Instructions and all applicable Standards. Failure to follow these Instructions and/ or Standards may cause property damage, personal injury, or loss of life.

Do not store or use gasoline or other flammable vapors and liquids in the vicinity of this control or other appliances.

WHAT TO DO IF YOU SMELL GAS

- Do not operate any appliance.
- Do not touch any electrical switch; do not use any phone in your building.
- Immediately evacuate the area and contact the gas supplier. Follow the gas supplier's instructions.
- If you cannot reach the gas supplier, call the fire department.

Installation and service must be performed by a qualified installer, service agency, or the gas supplier. Installation shall conform with local codes, or in the absence of local codes, in accordance with the National Fuel Gas Code ANSI Z223.1/NFPA 54 or the IFGC or CSA B149.1. All piping and tubing must comply with local codes and ordinances.

Use only your hand to push in or turn the gas control knobs. Never use tools. If a knob will not push in or turn by hand, do not try to repair it. Call a qualified service technician. Force or attempted repair can result in a fire or explosion.

Do **NOT** use this control or any gas appliance if any part has been under water or in contact with water. Immediately call a qualified service technician to replace the control system and any gas control that has been under water or in contact with water.

▲ WARNING

ELECTRIC SHOCK HAZARD

- Read these instructions carefully. Failure to follow them could result in property damage, personal injury, or loss of life.
- This control must be electrically wired and operated in accordance with all codes and local regulations. Service and installation must be performed by a trained, experienced service technician.
- Do not use the control if you suspect it may be damaged.

1. General Notes

This Mendip gas appliance is a High Efficiency, Balanced Flue Live Fuel Effect appliance. It provides radiant and convected heat using the latest burner technology. As well as having a variable heat output, these fires also utilise a special control system that allows the appliance to use three burners for high output or a single burner for lower outputs.

The Front Burner will be designated as the "Main" Burner, the second, rear burner, will be designated as the "Effect" Burners. The Effect burner can be switched ON or Off whilst the appliance is alight.

Before Installation, check that the local distribution conditions, nature of the gas and pressure, and adjustment of the appliance are compatible.

This appliance is intended for use on a gas installation with a governed meter.

This Gas Installation **may only be installed by a registered professional competent person (Gas Safe installer in the UK)**. The installation must adhere to the requirements of the local and national Building regulations and national standards. The installation manual must also be followed.

Ensure that the Flue Terminal is not in any way obstructed and is clear of vegetation, i.e. trees, shrubs etc. and that no objects are leant against the terminal or guard.

Always clean the Window Panel before the fire is ignited. Any finger prints must be removed, as these will be burnt into the glass and will be un-removable.

Do not operate this appliance if the glass panel has been broken (or cracked), removed or is open.

The appliance is designed to fit numerous installation situations as listed in these installation instructions. However only flue approved by Mendip for this appliance may be used.

This appliance is a balanced flue product and is room sealed and as such requires no additional ventilation for operation. However an adequate supply of fresh air to maintain temperatures and a comfortable environment is recommended.

This appliance is designed as a heating appliance, and as such will get very hot in operation; all surfaces (except the controls and access door) are considered to be working surfaces and as such should not be touched. The front windows and surrounds are not considered to be fully secure guards against accidental contact. It is recommended that an approved fire screen be used if children, the elderly or persons with limited mobility are to be present in the same area.

Do not place curtains, laundry, furniture etc. within a safe distance of 300mm of this appliance.

Do not attempt to burn rubbish on this appliance.

If this appliance is extinguished, on purpose or other, no attempt to relight should be made within 3 minutes.

Flue Systems

Mendip products are approved for use with the following Flue Systems (inc. types C11, C31 and C91):

Metaloterm US.

Muelink & Grol (M&G) Concentric.

Poujoulat PGI.

Jeremias TWG (System TWIN-GAS).

Flexinox (Thermo Products BV) Thermovent Con.

2. User instructions.

2.1 Emergency Gas Isolation

In the event of a gas leak or if gas is smelt, the appliance must be isolated. This is done by turning OFF the gas at the Isolation Tap. This Isolation Tap is located in the foot of the appliance.

2.2 First Time of Operation



Before igniting the appliance, ensure that all packaging, safety stickers and any protective wrapping have been removed, and that the glass has been cleaned, including all fingerprints from the glass.

Ensure that the room is adequately ventilated the first time that the appliance is ignited; we would recommend opening windows if possible. Run the appliance at full setting for a few hours so that the paint gets an opportunity to fully cure. During this period it is possible for some fumes and vapours to be given off. We would recommend keeping children and pets out of the area at this time.

2.3 Control Overview

2.3.1 Basic Manual Control

(Only possible, when MANUAL knob is used) Access to the pilot burner is only required for ignition with a match. When turning main valve knob, do not force. Knob has a slip clutch that clicks until the end stops are reached. This allows for manual flame height adjustment as well as adjustment to pilot standby position.

1. **STOP!** Read the safety information included before proceeding.
2. Turn main valve knob to the **OFF**, full clockwise position. 
3. Turn MANUAL knob to the **MAN**, full clockwise position. 
4. Wait five (5) minutes to clear out any gas. Verify that no gas is in the area around the appliance, including near the floor. **If you detect gas stop! follow “What to do if you smell gas” in the safety information on page 4.** If no gas is present, proceed to step 5.
5. With the MANUAL knob in man position a manual pilot valve operator and piezo ignitor (optional) are accessible.
6. Fully push down manual pilot valve operator and hold in, to start pilot gas flow (see figure 25, page 21).
Ignition with match: immediately light the pilot with a match, while continuing to hold in the manual pilot valve operator for about one (1) minute after the pilot is lit. Release manual pilot valve operator. if pilot does not stay lit, wait five (5) minutes and repeat.

2.3.2 Remote Control

OPERATING INSTRUCTIONS

GENERAL NOTES

NOTICE

Wiring of valve and receiver must be completed before starting ignition. Failure to do so could damage the electronics.

Batteries – Handset

- Low battery indicator on handsets.



Batteries – Receiver

- Low battery indication: frequent beeps for 3 seconds when motor turns.
- An AC Mains Adapter may be used instead of batteries.
- The module for fan speed control and light/dimmer includes mains power together with batteries in the receiver for automatic backup in case of power outage.

▲ WARNING

- Without using a mains adapter, battery replacement is recommended at the beginning of each heating season.
- Old or dead batteries should be removed immediately. If left in the unit the batteries can overheat, leak, and/or explode.
- Do NOT expose batteries (including during storage) to direct sunlight, excessive heat, fire, moisture, or severe impact. Each of these conditions can cause the batteries to overheat, leak, and/or explode.
- New and old batteries and different brands of batteries should not be used together. Mixing of various batteries can cause the batteries to overheat, leak, and/or explode.

Software Version

Press  and  buttons simultaneously. Software version is displayed.

Handset Model Number

Press  and  buttons simultaneously. Handset model number is displayed.

Deactivate Functions

1. Install batteries. All icons are displayed and flashing.
2. While the icons are flashing, press the relevant function button and hold for 10 sec.
3. The function icon will flash until deactivation is complete. Deactivation is complete when the function icon and two horizontal bars are displayed.

NOTE: If a deactivated button is pressed, there is no function, and two horizontal bars are displayed.

NOTE: Deactivation remains in effect after change of batteries.

Activate Functions

1. Install batteries. All icons are displayed and flashing.
2. To activate a function, press the relevant button and hold for 10 sec.
3. The function icon will continue to flash until activation is complete. Activation is complete when the function icon is displayed.

The following Functions can be Deactivated/Activated

- CHILD PROOF
- PROGRAM MODE
- THERMOSTATIC MODE (also deactivates PROGRAM MODE)
- ECO MODE

- LIGHT/DIMMER OPERATION
- CIRCULATING FAN OPERATION
- AUXILIARY FEATURE
- COUNTDOWN TIMER

SETTING THE ELECTRONIC CODE

(First time use only.)

Radio Frequency Handset

A code is selected automatically for all Mertik Maxitrol electronics from among 65,000 random codes available. The receiver has to learn the code of the handset:

- Press and hold the receiver's reset button (see figure 22) until you hear two (2) beeps. The first beep is short, and the second beep is long. After the second beep, release the reset button.
- Within the subsequent 20 seconds press the (small flame) button on the handset until you hear two additional short beeps confirming the code is set. If you hear one long beep, this indicates the code learning sequence has failed or the wiring is incorrect.

note: This is a one time setting only, and is not required after changing the batteries of the handset or receiver.

Figure 22: Receiver Reset Button

NOTICE

Replacement handsets for CsA models also must have the same part number (see label).

NOTICE

Only the Mertik Maxitrol AC Mains Adapter or one preapproved by Mertik Maxitrol can be used. Use of other adaptors can render the system inoperable.

NOTE: This is a one time setting only, and is not required after changing the batteries of the handset or receiver.



Figure 22: Receiver Reset Button

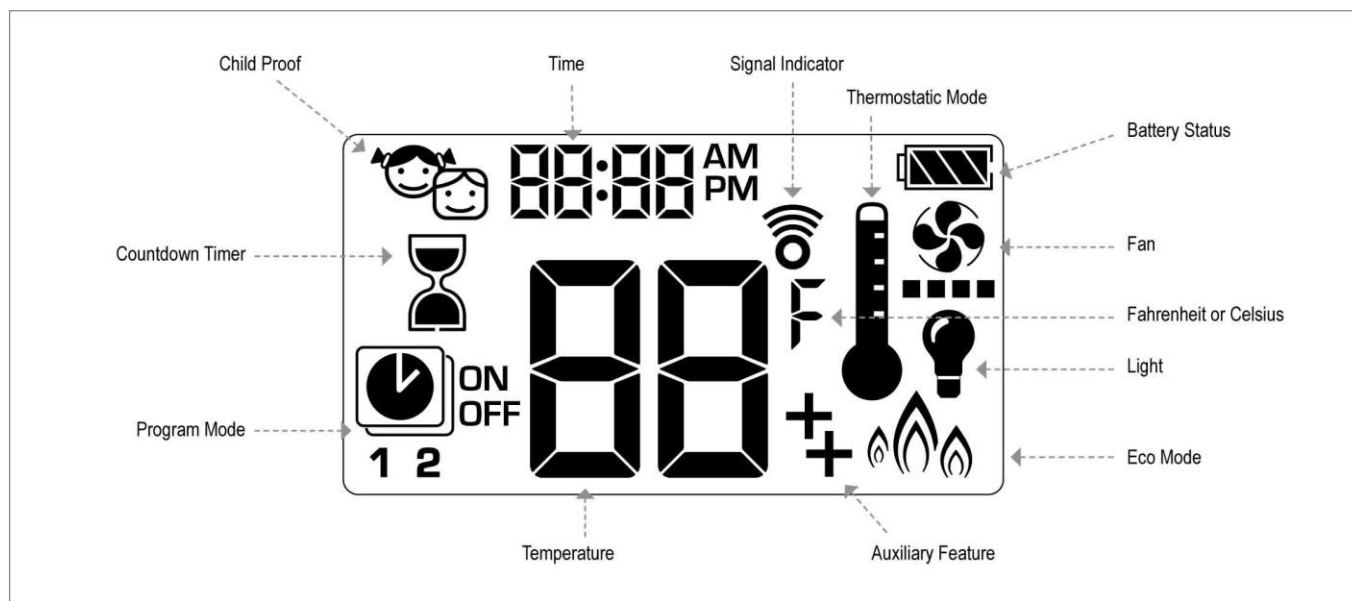

Figure 29: 10-symbol Display

SETTING FAHRENHEIT or CELSIUS



To change between °C and °F, press and buttons simultaneously.

NOTE: Choosing °F results in a 12 hour clock. Choosing °C results in a 24 hour clock.

CHILD PROOF



ON:
To activate press and buttons simultaneously. displayed and the handset is rendered inoperable, except for the off function.

OFF:
To deactivate press and buttons simultaneously. disappears.

SETTING the TIME



1. Press and buttons simultaneously. **Day** flashes.
2. Press or button to select a number to correspond with the day of the week (e.g. 1=Monday, 2=Tuesday, 3=Wednesday, 4=Thursday, 5=Friday, 6=Saturday, 7=Sunday).
3. Press and buttons simultaneously. **Hour** flashes.
4. To select hour press or button.
5. Press and buttons simultaneously. **Minutes** flash.
6. To select minutes press or button.
7. To confirm press and buttons simultaneously or wait.

MANUAL MODE (HANDSET)

NOTICE

BEFORE OPERATING

1. Make sure MANUAL knob on the GV60 valve is in the **ON**, full counterclockwise ↶ position.
2. Place the ON/OFF switch (if equipped) in the **I (ON)** position.

TO TURN ON FIRE

⚠ WARNING

When pilot ignition is confirmed, motor turns automatically to maximum flame height.

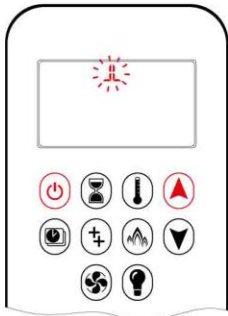

- Press ⏻ button (One Button Ignition) or ⏻ and ▲ button simultaneously (Two Button Ignition) until two short beeps and a blinking series of lines confirms the start sequence has begun; release button(s).
- Main gas flows once pilot ignition is confirmed.
- Handset automatically goes into Manual Mode after main burner ignition.

⚠ WARNING

If the pilot does not stay lit after several tries, turn the main valve knob to **OFF** and follow the instructions “TURN OFF GAS TO APPLIANCE”

STANDBY MODE (PILOT FLAME)

Handset

- Press and hold ▼ button to set appliance to pilot flame.

TO TURN OFF FIRE



Handset

- Press ⏻ button to turn off.

NOTE: A new ignition is possible after the OFF icon stops flashing.

FLAME HEIGHT ADJUSTMENT



Handset

- To increase flame height press and hold ▲ button.
- To decrease flame height or to set appliance to pilot flame, press and hold ▼ button.

DESIGNATED LOW FIRE and HIGH FIRE

NOTE: Backlight must be on for high fire and low fire double-click operation.



- To go to low fire, double-click ▼ button. **LO** is displayed.

NOTE: Flame goes to high fire first before going to low fire.



- To go to high fire, double-click ▲ button. **HI** is displayed.

⚠ WARNING

If the appliance will not operate, follow the instructions “TURN OFF GAS TO APPLIANCE”

COUNTDOWN TIMER



ON/SETTING:

1. Press and hold ⏻ button until ⏻ displayed, and **hour** flashes.
2. To select hour press ▲ or ▼ button.
3. To confirm press ⏻ button. **Minutes** flash.
4. To select minutes press ▲ or ▼ button.
5. To confirm press ⏻ button or wait.

OFF:

Press ⏻ button, ⏻ and countdown time disappear.

NOTE: At end of countdown time period, the fire shuts off. The Countdown Timer only works in Manual, Thermostatic, and Eco Modes. Maximum countdown time is 9 hours and 50 minutes.

MODES of OPERATION

Thermostatic Mode

The room temperature is measured and compared to the set temperature. The flame height is then automatically adjusted to achieve the set temperature.



Program Mode

Programs 1 and 2, each can be programmed to go on and off at specific times at a set temperature.



Eco Mode

Flame height modulates between high and low. If the room temperature is lower than the set temperature, the flame height stays on high for a longer period of time. If the room temperature is higher than the set temperature, the flame height stays on low for a longer period of time. One cycle lasts approx. 20 min.



THERMOSTATIC MODE

ON:

Press button. displayed, preset temperature displayed briefly, and then room temperature displayed.



OFF:

1. Press button.
2. Press or button to enter Manual Mode.
3. Press button to enter Program Mode.
4. Press button to enter Eco Mode.

SETTING:

1. Press button and hold until displayed, temperature flashes.
2. To adjust set temperature press or button.
3. To confirm press button or wait.



PROGRAM MODE

ON:

Press button. , 1 or 2, ON or OFF displayed.



OFF:

1. Press or button to enter Manual Mode.
2. Press button to enter Thermostatic Mode.
3. Press button to enter Eco Mode.



NOTE: The set temperature for Thermostatic Mode is the temperature for the on time in Program Mode. Changing the Thermostatic Mode set temperature also changes the on time temperature in Program Mode.

Default settings:

ON TIME (Thermostatic) TEMPERATURE: 21 °C (70 °F)
OFF TIME TEMPERATURE: "--" (pilot flame only)

TEMPERATURE SETTING:

1. Press button and hold until flashes. ON and set temperature (setting in Thermostatic Mode) displayed.
2. To continue press button or wait. , OFF displayed, temperature flashes.
3. Select off temperature by pressing the or button.
4. To confirm press button.



NOTE: The on (Thermostatic) and off set temperatures are the same for each day.

DAY SETTING:

5. ALL flashes. Press or button to choose between ALL, 5A-5U, 1, 2, 3, 4, 5, 6, 7.
6. To confirm press button.

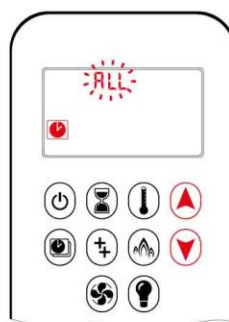

RLL SELECTED



- ON TIME SETTING (PROGRAM 1):**
7. **1, ON** displayed, RLL is displayed shortly, and **hour** flashes.
 8. To select hour press **▲** or **▼** button.
 9. To confirm press **⊙** button. **1, ON** displayed, RLL displayed shortly, and **minutes** flash.
 10. To select minutes press **▲** or **▼** button.
 11. To confirm press **⊙** button.



- OFF TIME SETTING (PROGRAM 1):**
12. **1, OFF** displayed, RLL is displayed shortly, and **hour** flashes.
 13. To select hour, press **▲** or **▼** button.
 14. To confirm press **⊙** button. **1, OFF** displayed, RLL displayed shortly, and **minutes** flash.
 15. To select minutes press **▲** or **▼** button.
 16. To confirm press **⊙** button.

NOTE: Either continue to PROGRAM 2 and set on and off times or stop programming at this point, and PROGRAM 2 remains deactivated.

NOTE: PROGRAM 1 and 2 use the same on (Thermostatic) and off temperatures for RLL, 5R5U and Daily Timer (1, 2, 3, 4, 5, 6, 7). Once a new on (Thermostatic) and/or off temperature has been set, that temperature becomes the new default setting.

NOTE: If RLL, 5R5U or Daily Timer are programmed for PROGRAM 1 and PROGRAM 2 on and off times, these become the new default times. The batteries must be removed to clear the PROGRAM 1 and PROGRAM 2 on and off times and temperatures.

5R5U or Daily Timer (1, 2, 3, 4, 5, 6, 7) selected

- Set on time and off time using same procedure as "RLL selected" (above).
- 5R5U: Set on time and off time for both Saturday and Sunday.
- Daily Timer: Unique on and off times may be set for a single day of the week, for multiple days of the week, or for every day of the week.
- Wait to finish setting.

AUXILIARY FEATURE

Upon ignition burner 1 is on and burner 2 is in the last setting.



- ON:**
To switch a burner on, press the **⊕** button. **⊕** displayed.
- OFF:**
To switch the burner off, press the **⊕** button. **⊕** disappears.

NOTE: The latching solenoid valve cannot operate manually. If the receiver battery runs down it will remain in the last operating position.

ECO MODE



- ON:**
Press **⊕** button to enter Eco Mode. **⊕** displayed.
- OFF:**
Press **⊕** button. **⊕** disappears.

CIRCULATING FAN OPERATION

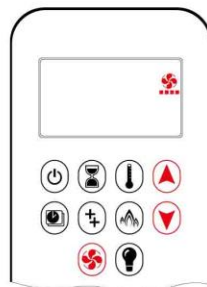

Circulating fan has 4 speed levels from low (1 bar) to high (4 bars).

- SETTING:**
1. Press **⊕** button and hold until **⊕** flashes.
 2. Press **▲** button to increase fan speed and **▼** button to decrease fan speed.
 3. To confirm setting either press **⊕** button or wait (**⊕** displayed).

OFF:
Press **▼** button until all 4 speed level bars disappear.

NOTE: SETTING only. If the fan was not switched off after last use, it starts automatically 4 minutes after ignition at maximum speed and goes to the last set level after 10 seconds. The fan stops 10 minutes after the gas is OFF or at pilot.

MYFIRE APP**NOTICE**

Before the App can be used, the myfire Wi-Fi Box must be wired and plugged into mains power according to myfire App setup diagram



If Thermostatic, Program or Eco Mode is activated, the corresponding icon and "APP" is displayed on the handset.

The modes can be operated according to the descriptions on previous pages.

NOTE: In Manual Mode "APP" is NOT displayed on the handset.

2.4 Manual Turn OFF

In the event that the appliance needs to be turned OFF manually, for instance, if the remote control is lost or the batteries become totally flat, the control valve must be accessed and the switch flipped to OFF (marked "0").

The picture below shows the control valve.

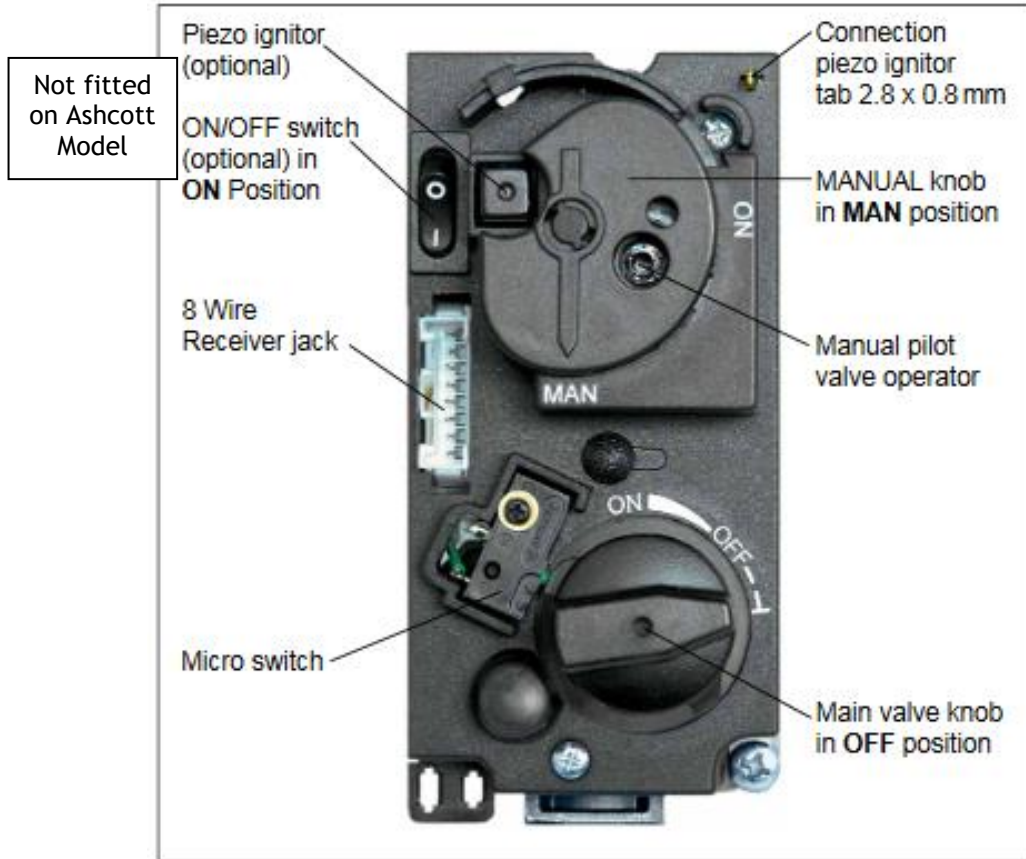

The control valve is located behind the control hatch in the Base of the appliance.

2.5 Cleaning and Maintenance

This appliance should be inspected and serviced once a year by a qualified, competent and registered person. The inspection and maintenance must at least ensure that the appliance is working correctly and safely. It is advisable to clean the appliance of any dust and debris before regularly during the heating season and especially if the appliance has not been used for some time. This can be done with a soft brush and a vacuum cleaner or a damp cloth and if required a non-abrasive cleaning agent. Do not use corrosive or abrasive substances to clean the appliance.

3. Installation instructions.

Before commencing Installation, confirm that the details on the appliance data plate correspond to the local distribution conditions, gas type and pressure to which the appliance is to be installed.

Ensure that gas supply and supply pipe is capable of delivering the required volume and pressure of gas and is in accordance with the rules in force.

3.1 Gas Connection

This appliance has a gas inlet connection of Ø 8mm.

3.2 Ventilation

This appliance is a Balanced Flue room sealed appliance, and as such needs no additional ventilation. However an adequate supply of fresh air to maintain temperatures and a comfortable environment is recommended.

This appliance may be installed in a completely sealed or mechanically ventilated house.

3.3 Appliance Fireplace Installation

Determine the position required for the appliance.

Create a gas connection for the appliance in approximately the correct location for the gas controls.

The gas controls are connected to the Burner of the appliance.

For clearance details see section 3.3.1. below.

The clearance distance of the Flue from combustibles must not be less than 75mm. This dimension can be reduced to 25mm as the distance from the underside and the sides of Horizontal Flue runs.

The stove must stand on a fireproof hearth, which must be of a non-combustible material with a minimum thickness of 12mm and extend 100mm in front of the stove.

The hearth must not be capable of inadvertent covering by a rug or carpet. This may be achieved by either the hearth being 50mm above the level of the floor, or a fender or kerb around the hearth to a height of 50mm.

3.3.1 Clearance requirements

The appliance must not be fitted against a rear wall constructed from a combustible material; a gap of 300mm should be given around the stove before combustible materials may be used in the wall construction.

If the appliance has to be located in an opening, the minimum clearance from non-combustible materials is:

To Rear : 50mm

To Right : 50mm

To Left : 50mm

The stove must be located at least 280mm from any combustible materials.

A combustible shelf may be fitted over the appliance, if in the case of a 150mm or less deep shelf, there is at least 280mm clearance above the top of the stove. The shelf depth may increase at the same rate as the increase in clearance; i.e. a shelf depth of 200mm would require a clearance of 330mm.

3.4 Flue Connection

3.4.1 General notes

This appliance may be installed with a roof terminal (C31) or a wall terminal (C11).

This appliance may only be used with Balanced Flue (otherwise known as Concentric Flue) parts as specified by Mendip. The Mendip specified flue parts have been approved with the appliance. If the appliance is installed on non-Mendip approved parts, Mendip cannot guarantee or accept responsibility for the proper and safe working of the appliance.

Approved Flue Systems are listed on Page 4.

The flue system must be constructed from the appliance upwards, with all joints being fully locked and sealed using the Mendip specified parts.

3.4.2 Timber Frame Construction

Whilst it is possible to install room-sealed appliances in timber frame properties, great care needs to be taken to ensure that the flue assembly does not interfere with the weather proofing qualities of any outer wall which it may penetrate. Before attempting this work, further details need to be referenced, (e.g. "Gas Installations in Timber Frame Buildings" from the GAS SAFE installer series in the UK).

3.4.3 Carport or Building Extension

Where a flue terminal is sited within a carport or building extension, it should have at least two completely open and unobstructed sides. The distance between the lowest part of the roof and the top of the terminal should be at least 600mm.

Note: A covered passageway should not be treated as a carport. Flues should not be sited in a covered passageway between properties.

3.4.4 Basements, Lightwells and Retaining walls

Flue terminals should not be sited within the confines of a basement area, light well or external space formed by a retaining wall, unless steps are taken to ensure the products of combustion can disperse safely at all times. It may be possible to install this Balanced Flue system in such a location provided that it is not sited lower than 1m from the top level of that area to allow combustion products to disperse safely.

Flue terminals should be sited to ensure total clearance of the combustion products in accordance with the included information.

When the products of combustion are discharged, they should not cause a nuisance to adjoining or adjacent properties and they should be positioned so that damage cannot occur to other parts of the building. If the outer wall surface is constructed of combustible material, a non-combustible plate should be fitted behind the terminal projecting 25mm beyond the external edges of the terminal.

3.4.5 Terminal Locations.

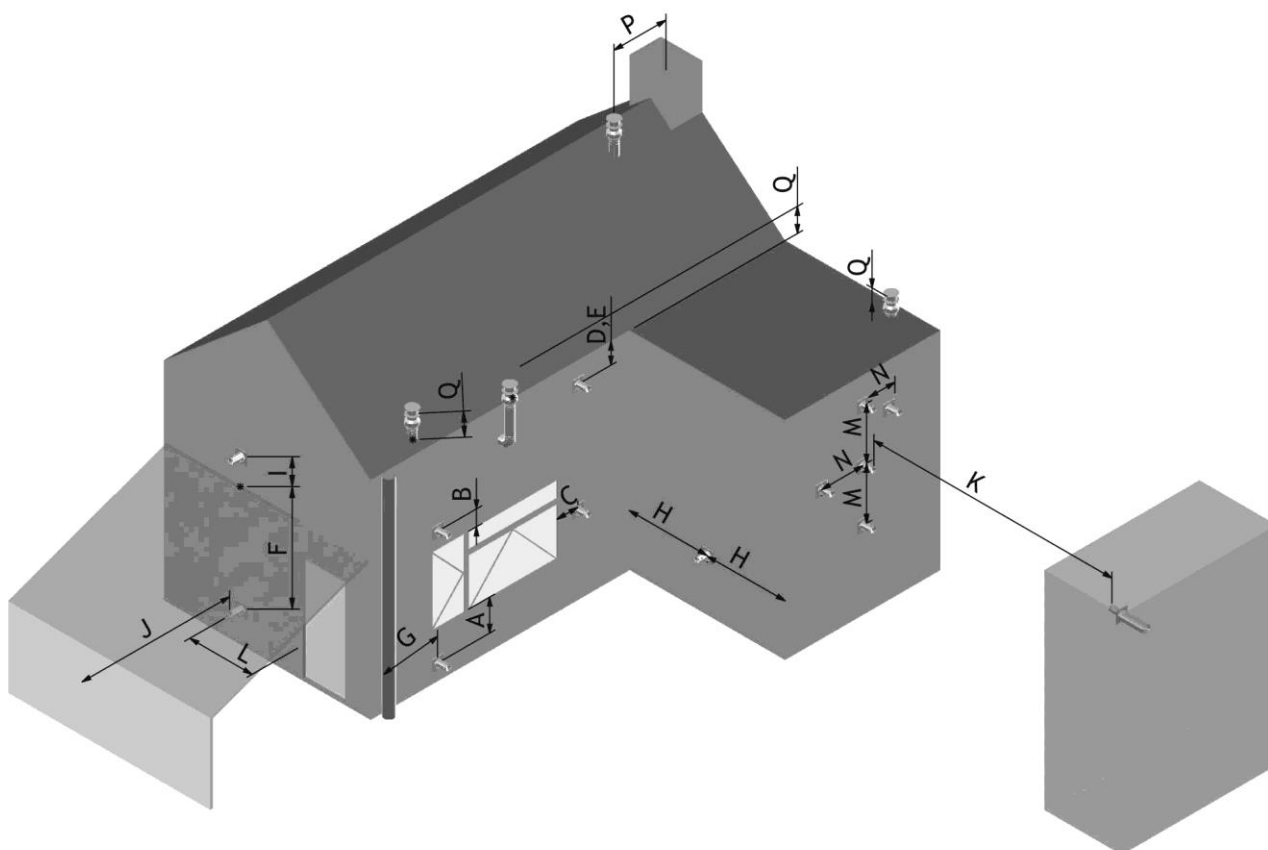

Dimension	Terminal Position	Distance (mm)
A*	Directly below an opening, air brick, opening window etc.	600
B	Above an opening, air brick, opening window etc.	300
C	Adjacent to an opening, air brick, opening window etc.	400
D	Below gutters, soil pipes or drain pipes	300
E	Below eaves	300
F	Below balconies of car port roof	600
G	From a vertical drain pipe or soil pipe	300
H	From an internal or external corner	600
I	Above ground roof or balcony level	300
J	From a surface facing the terminal	600
K	From a terminal facing the terminal	600
L	From an opening in the car port (e.g. door, window into the dwelling)	1200
M	Vertically from a terminal on the same wall	1500
N	Horizontally from a terminal on the same wall	300
P	From a vertical structure on the roof	600
Q	Above intersection with roof	150

* In addition, the terminal should not be nearer than 300mm to an opening in the building fabric formed for the purpose of accommodating a built in element such as a window frame.

3.4.6 Horizontal Wall Vent Termination type C₁₁

Flue sizing:

ASHCOTT : Ø100/150 Connector on Appliance.
 Ø100/150 Maybe used Throughout, Alternatively,
 Ø130/200 Expander may be used, so that Ø130/200 flue
 can be used thereafter.

Flue Terminal: Ø130/200 Part No. USDHC 130
 Ø100/150 Part No. USDHC 100

Maximum pipe extension, for outside wall (H)

= 4 X Vertical Pipe Rise (V) -1. For Ø130/200 flue.

= 2 X Vertical Pipe Rise (V) . For Ø100/150 flue.

Maximum Permissible run (H) =15m.

Vertical Flue Rise (V) metres	Max. Horizontal Flue Run, (H) m for Ø130/200 flue	Max. Horizontal Flue Run, (H) m for Ø100/150 flue
0.5	1	1
1	3	2
1.5	5	3
2	7	4
2.5	9	5
3	11	6
3.5	13	7
4	15	8
4.5	15	9
5	15	10
5.5	15	11
6.5	15	13
7	15	14
7.5 and over	15	15

Minimum Vertical Flue Height: ASHCOTT - 0.5m

Flue Restrictors to be fitted, Ø100/150:

	Ashcott
Vertical Rise < 1m	No Restrictor
Vertical Rise 1-2m	35mm Restrictor
Vertical Rise > 2m	50mm Restrictor

3.4.7 Vertical Roof Vent Termination C₃₁

Flue sizing:

ASHCOTT	:	Ø100/150	Connector on Appliance. The Ashcott needs a starter adapter. Code F90000-71-94-30-00
		Ø100/150	Maybe used Throughout, Alternatively,
		Ø130/200	Expander may be used, so that Ø130/200 flue can be used thereafter.
Flue Terminal:		Ø100/150	Code. F90000-71-17-30-00

Minimum Vertical Flue Height: ASHCOTT- 0.5m

Flue Restrictors to be fitted, Ø100/150:

	ASHCOTT
Vertical Rise < 1m	No Restrictor
Vertical Rise 1-2m	35mm Restrictor
Vertical Rise > 2m	50mm Restrictor

Vertical rise restrictors are fitted the to the flue exit fixings as shown in Fig1

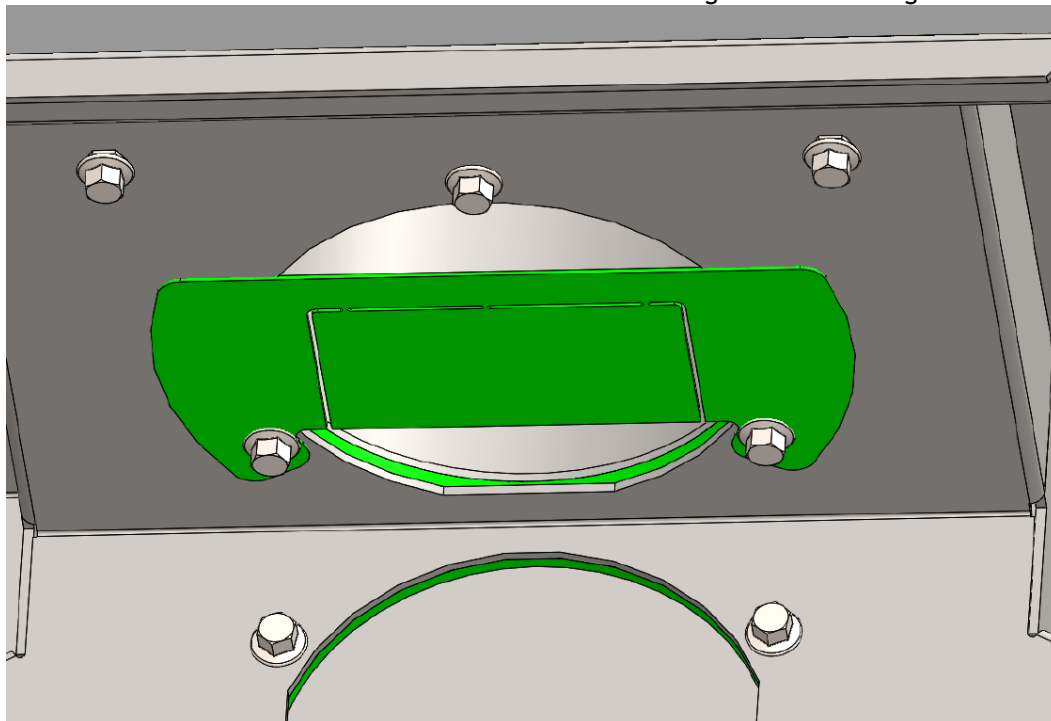

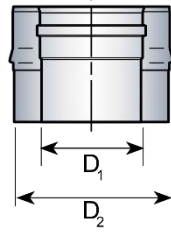

Mendip Stoves

Mendip stoves starter adapter	
Ø	100 / 150
REF.	
CODE	F90000-71-94-30-00
D ₁	99.7
D ₂	151.6

LENGTHS



Ø 100 / 150

250MM STRAIGHT LENGTH

REF.	ED250 100 DG
CODE	34 100 403
H	250

450MM STRAIGHT LENGTH

REF.	ED450 100 DG
CODE	34 100 404
H	450

950MM STRAIGHT LENGTH

REF.	ED1000 100 DG
CODE	34 100 405
H	950

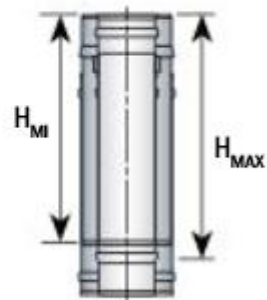

390 TO 640MM ADJUSTABLE LENGTH

REF.	ER 100 DG
CODE	34 100 429
H _{MIN}	390
H _{MAX}	640

ELBOWS

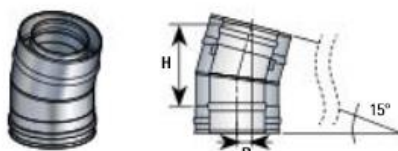

Ø	100 / 150
15° ELBOW	
REF.	EC15 100 DG
CODE	34 100 401
H	152
D	26

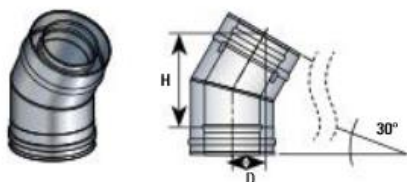

30° ELBOW	
REF.	EC30 100 DG
CODE	34 100 411
H	176
D	60

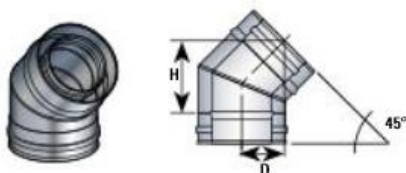

45° ELBOW	
REF.	EC45 100 DG
CODE	34 100 421
H	128
D	71

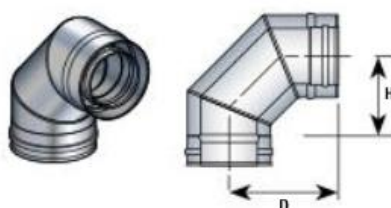

90° ELBOW	
REF.	EC90 100 DG
CODE	34 100 441
H	147
D	193

TERMINALS

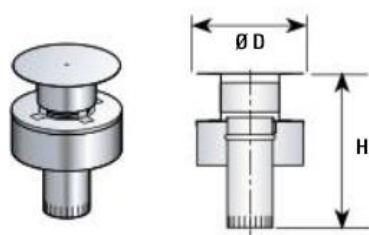

Ø	100 / 150
RAIN CAP	
REF.	CTIV G 100 DG
CODE	34 100 654
H	155
ØD	200

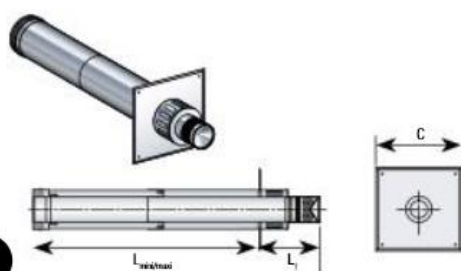

ADJUSTABLE HORIZONTAL TERMINAL	
REF.	STHR G 100 DG
CODE	34 100 610
L mini/maxi	360 to 630
L ₁	173
C x C	220 x 220

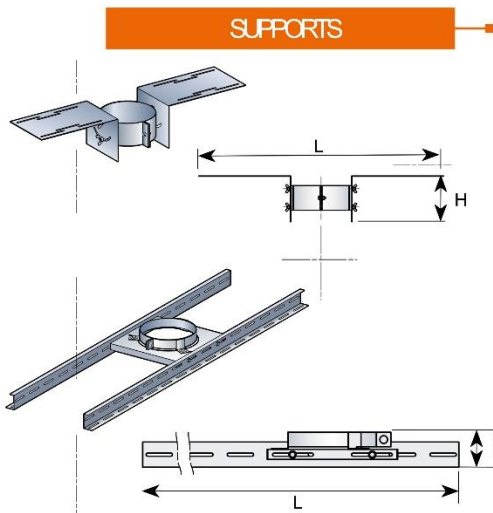

SUPPORTS

Ø	100 / 150	130 / 200	150 / 200
RAFTER SUPPORT			
REF:	SAT 150 SLCD	SAT 200 SLCD	
CODE	45 150 165	45 200 165	
H	150	150	
L	773	824	

JOIST SUPPORT			
REF:	SP 150 SLCD	SP 200 SLCD	
CODE	45 150 081	45 200 081	
H	80	80	
L	1250	1250	

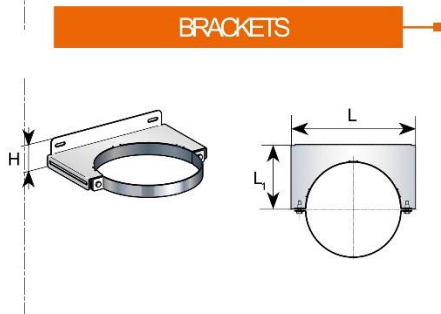

BRACKETS

Ø	100 / 150	130 / 200	150 / 200
WALL BRACKET			
REF:	CMI 150 SLCD	CMI 200 SLCD	
CODE	45 150 175	45 200 175	
H	70	70	
L	233	284	
L ₁	120	145	

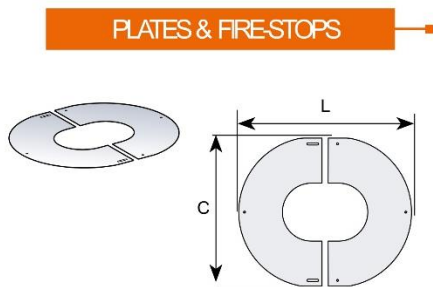

PLATES & FIRE-STOPS

Ø	100 / 150	130 / 200	150 / 200
STAINLESS STEEL WALL PLATE			
REF:0° to 10°	PP(I) 0/10 150 SLCD	PP(I) 0/10 200 SLCD	
CODE	45 150 105	45 200 105	
CxL	435 x 435	485 x 485	
REF:10° to 30°	PP(I) 10/30 150 SLCD	PP(I) 10/30 200 SLCD	
CODE	45 150 106	45 200 106	
CxL	440 x 430	490 x 480	
REF:30° to 40°	PP(I) 30/40 150 SLCD	PP(I) 30/40 200 SLCD	
CODE	45 150 107	45 200 107	
CxL	500 x 470	560 x 520	
REF:40° to 50°	PP(I) 40/50 150 SLCD	PP(I) 40/50 200 SLCD	
CODE	45 150 108	45 200 108	
CxL	530 x 470	600 x 520	

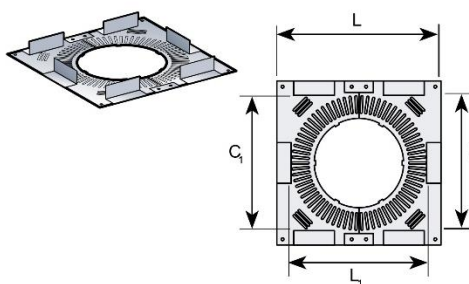

Ø	100 / 150	130 / 200	150 / 200
VENTILATED FIRESTOP			
REF:	PCF 150 SLCD	PCF 200 SLCD	
CODE	45 150 133	45 200 133	
L x C	311 x 311	362 x 362	
L ₁ x C ₁	276 x 276	327 x 327	

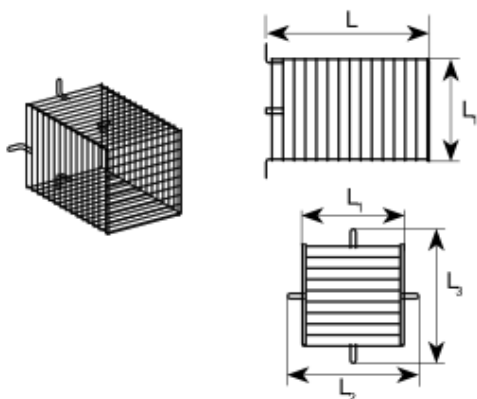

PROTECTION BASKET

REF:	PP 100EI 130 EI
CODE	17 100 160
L	283
L ₁	300
L ₂	350
L ₃	350

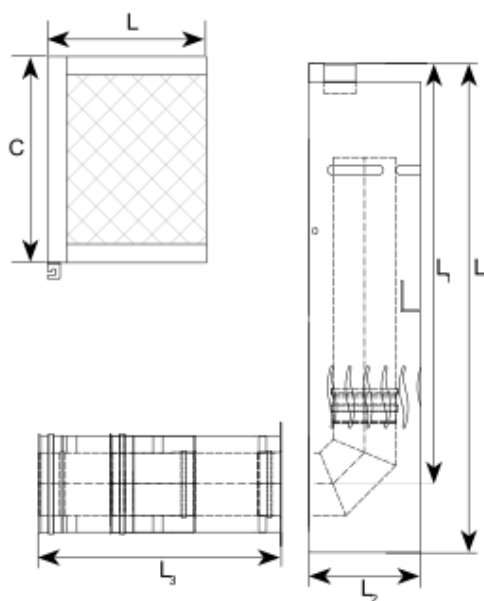

SNORKEL TERMINAL - CWV GUARD MESH & EXTENSION SECTION

REF:	SNO00 BIG
CODE	52 100 420
L	787
L ₁	677
L ₂	180
L ₃	350 to 550
C x L	333.5 x 256

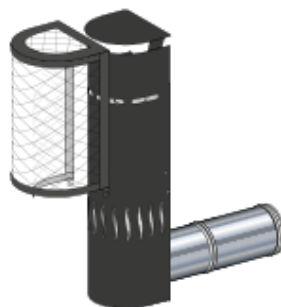

Vertical Roof Termination

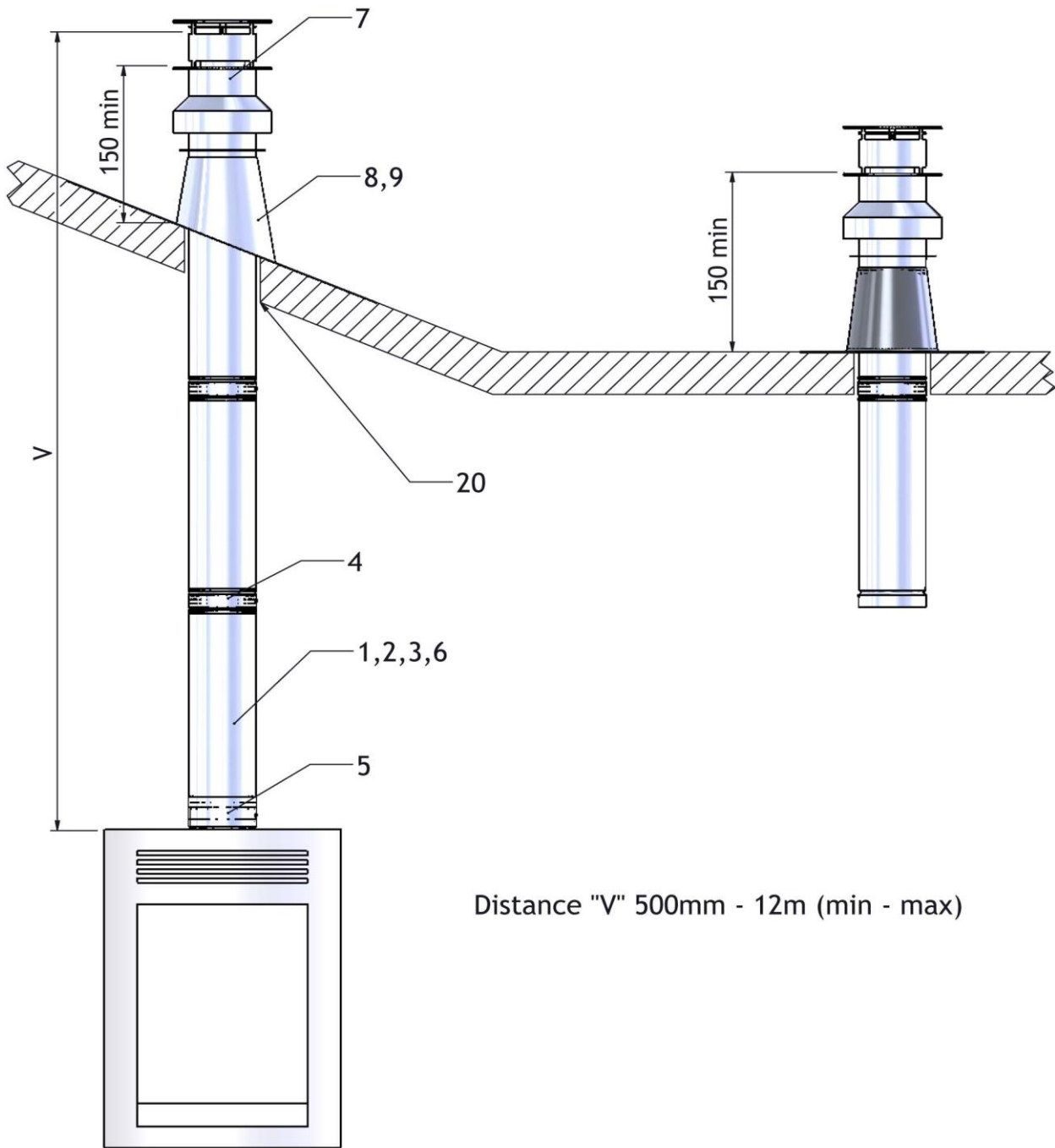

Distance "V" 500mm - 12m (min - max)

Vertical Roof Termination

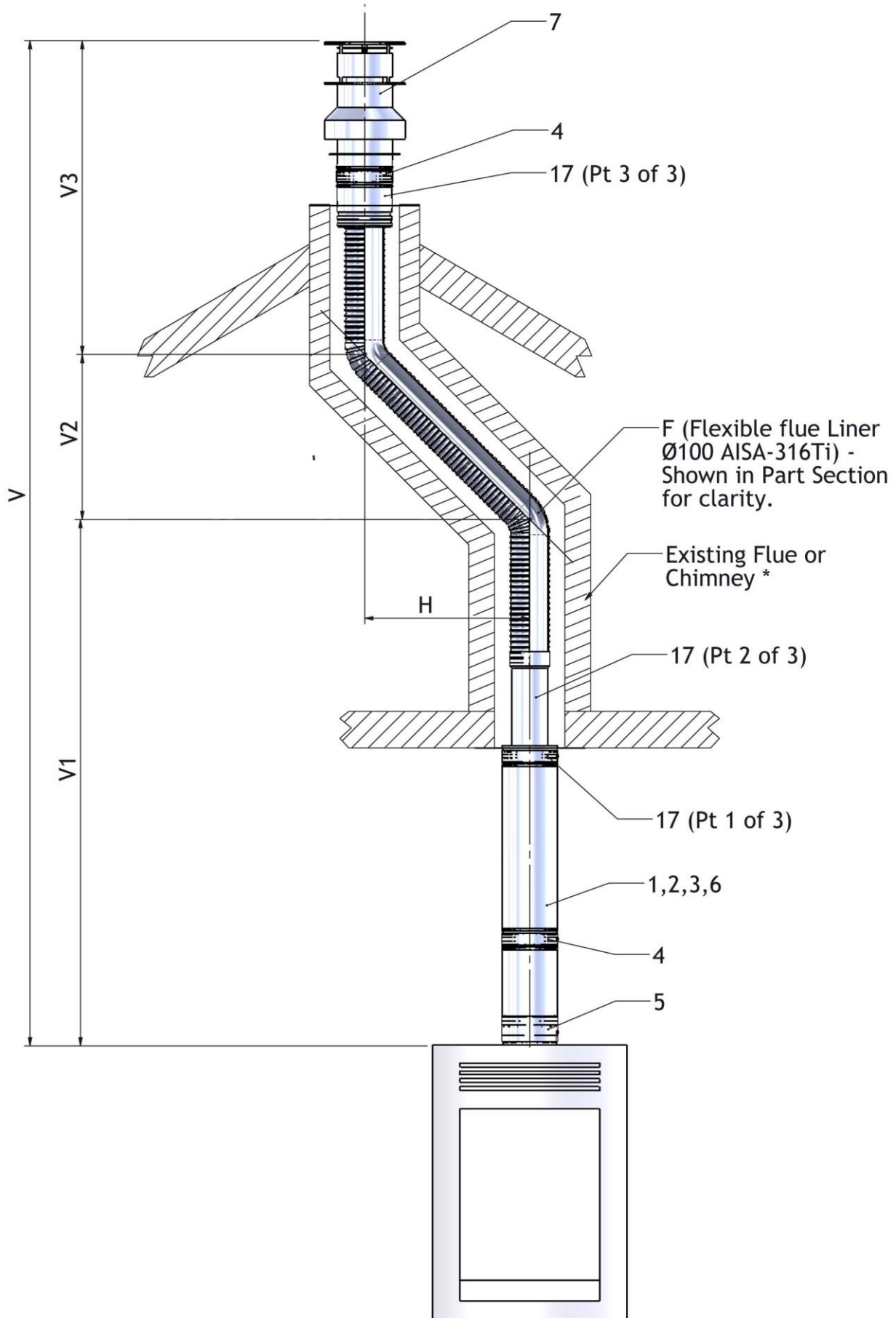

Vertical Roof Termination on angle

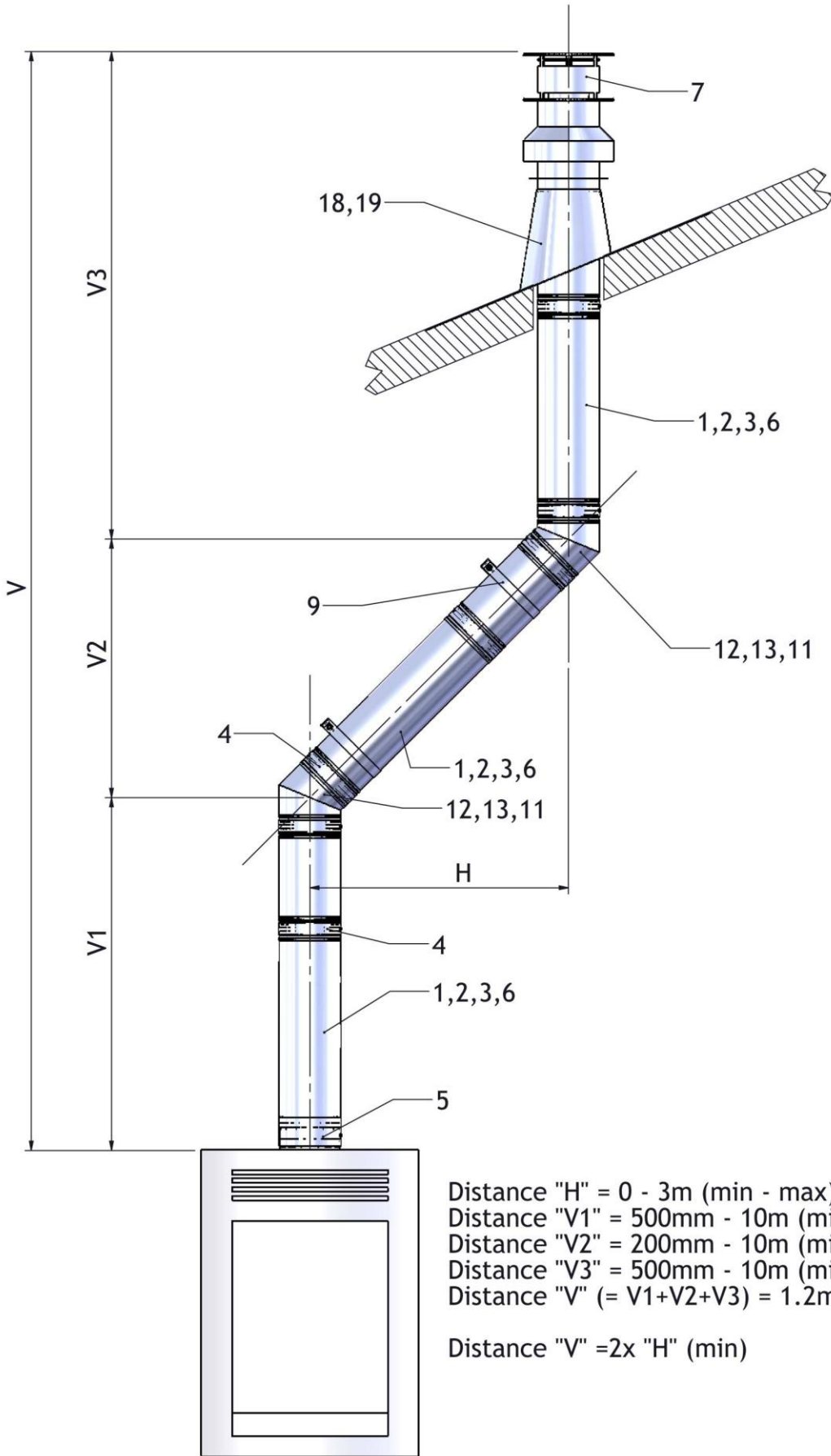

Vertical Roof Termination with bends

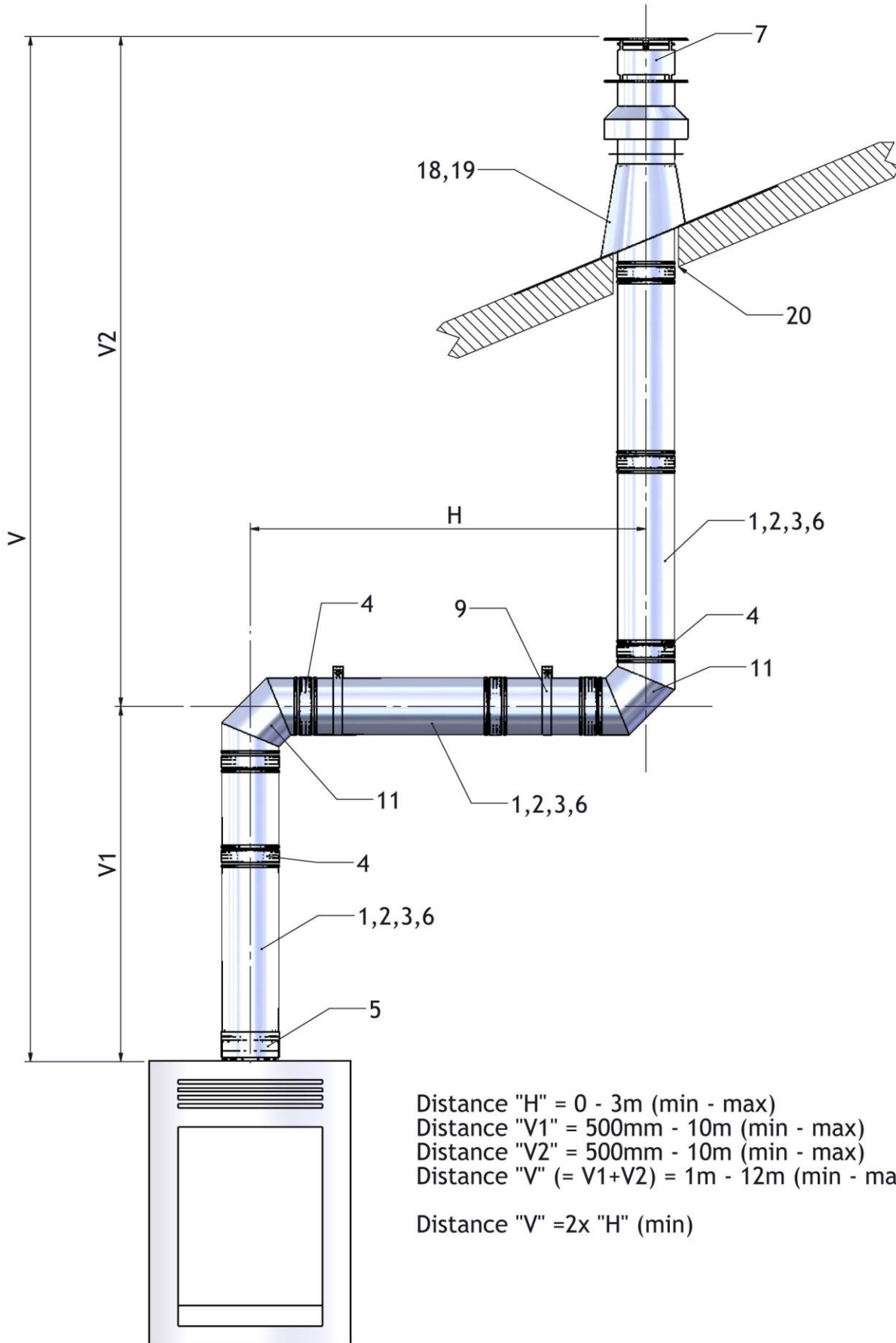

Distance "H" = 0 - 3m (min - max)
 Distance "V1" = 500mm - 10m (min - max)
 Distance "V2" = 500mm - 10m (min - max)
 Distance "V" (= V1+V2) = 1m - 12m (min - max)
 Distance "V" = 2x "H" (min)

Existing Chimney (Renevation Kit).

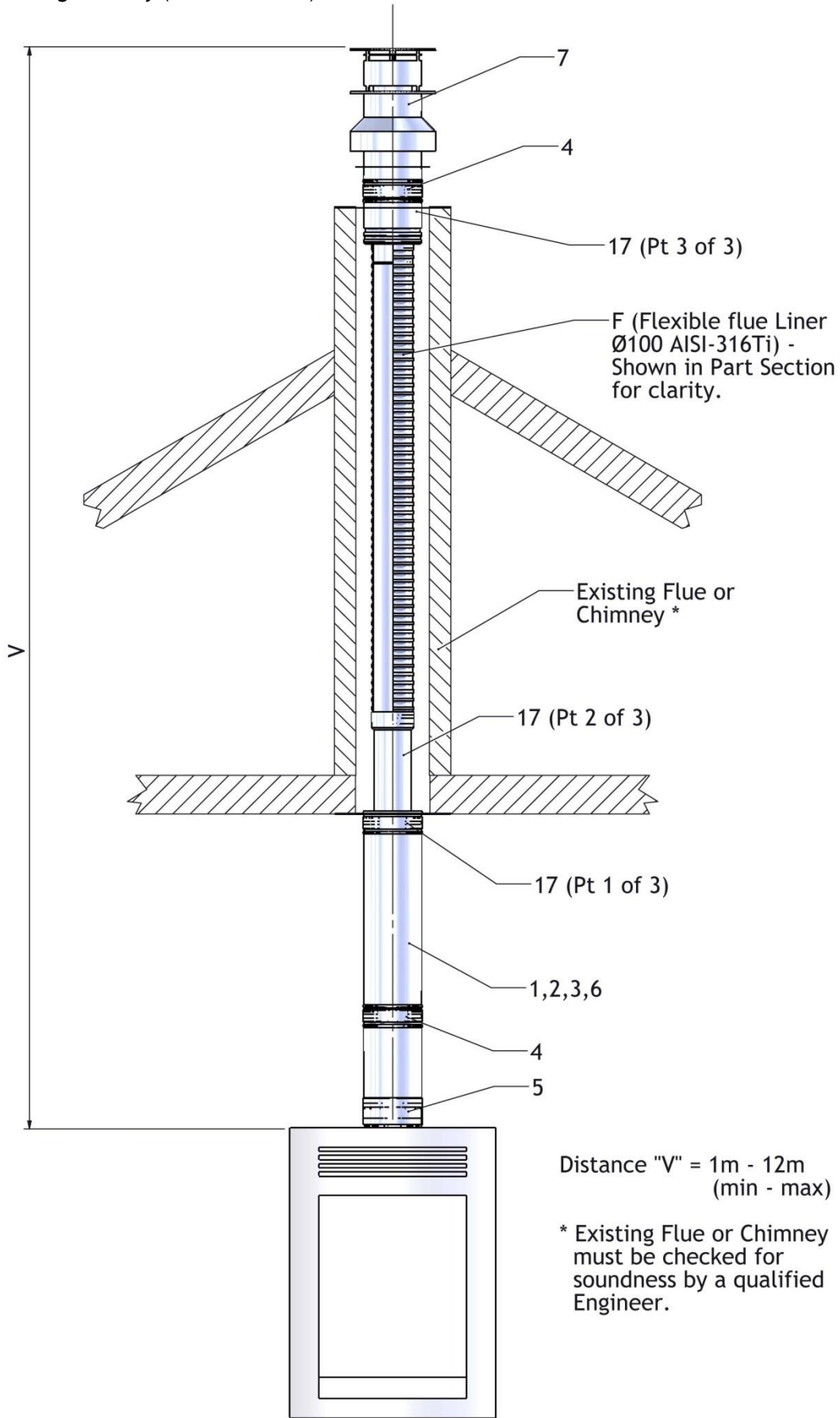

Existing Chimney with Bend (Renevation Kit).

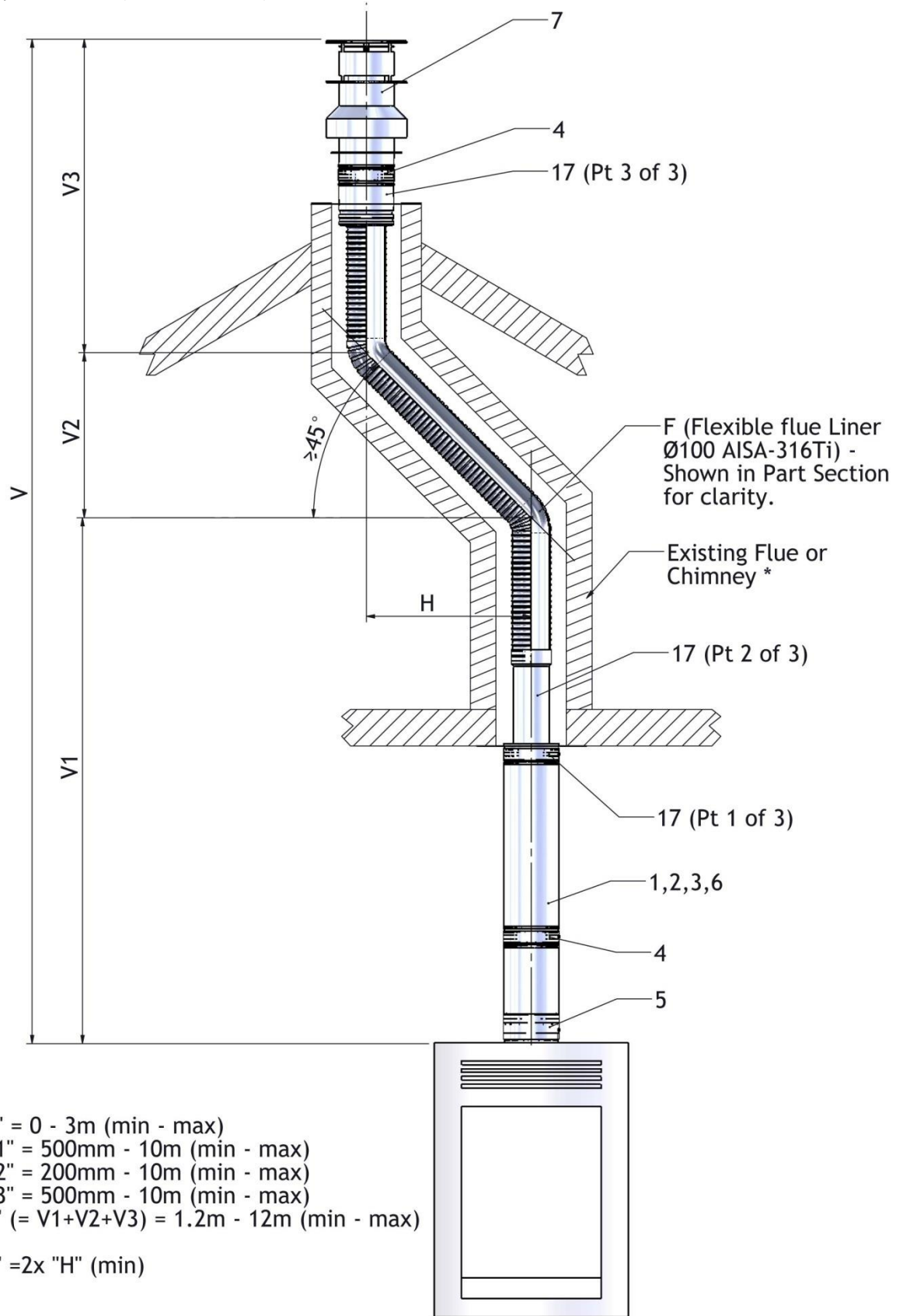

Horizontal, wall with Snorkel.

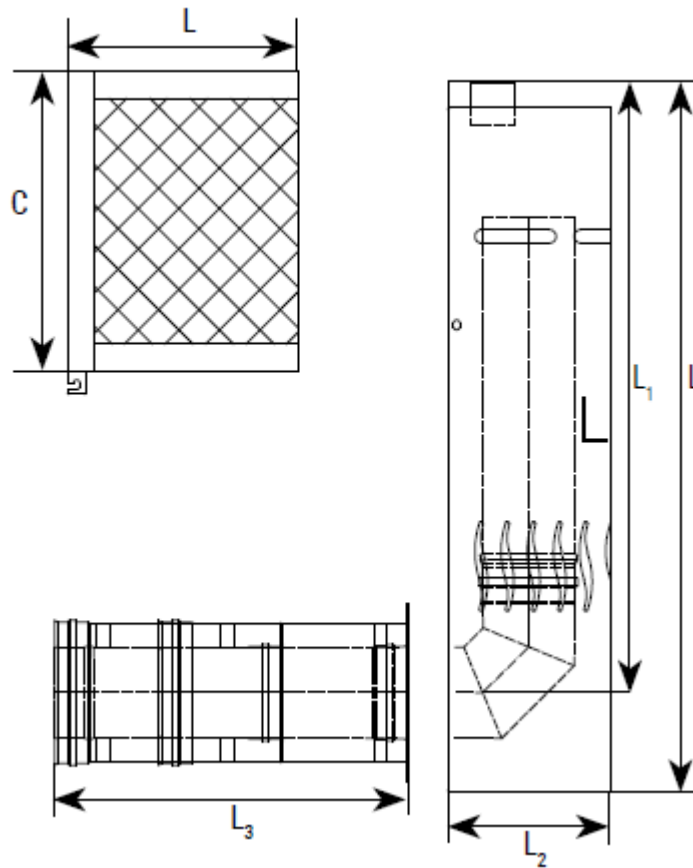

L	787
L ₁	677
L ₂	180
L ₃	350 to 550
C x L	333.5 x 256

Snorkel Distance "H" = 350-550mm excluding adapter. Adapter length 120mm

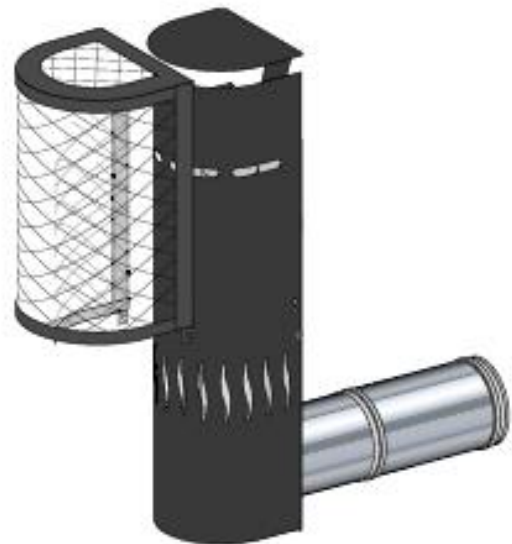

3.5 Fuel Bed Arrangements.

When arranging the Media into the Firebed, it is important that the Pilot area is kept clear and that no Media enters the Pilot shield. The Pilot area includes the the pilot shield and the top of the burner to the first slot.

When comissioning or servicing the Appliance Cross Lighting must be checked to ensure smooth lighting of the main burner from the Pilot Flame and smooth lighting of the effect burners from the main Burner.

3.5.1 Log Lay

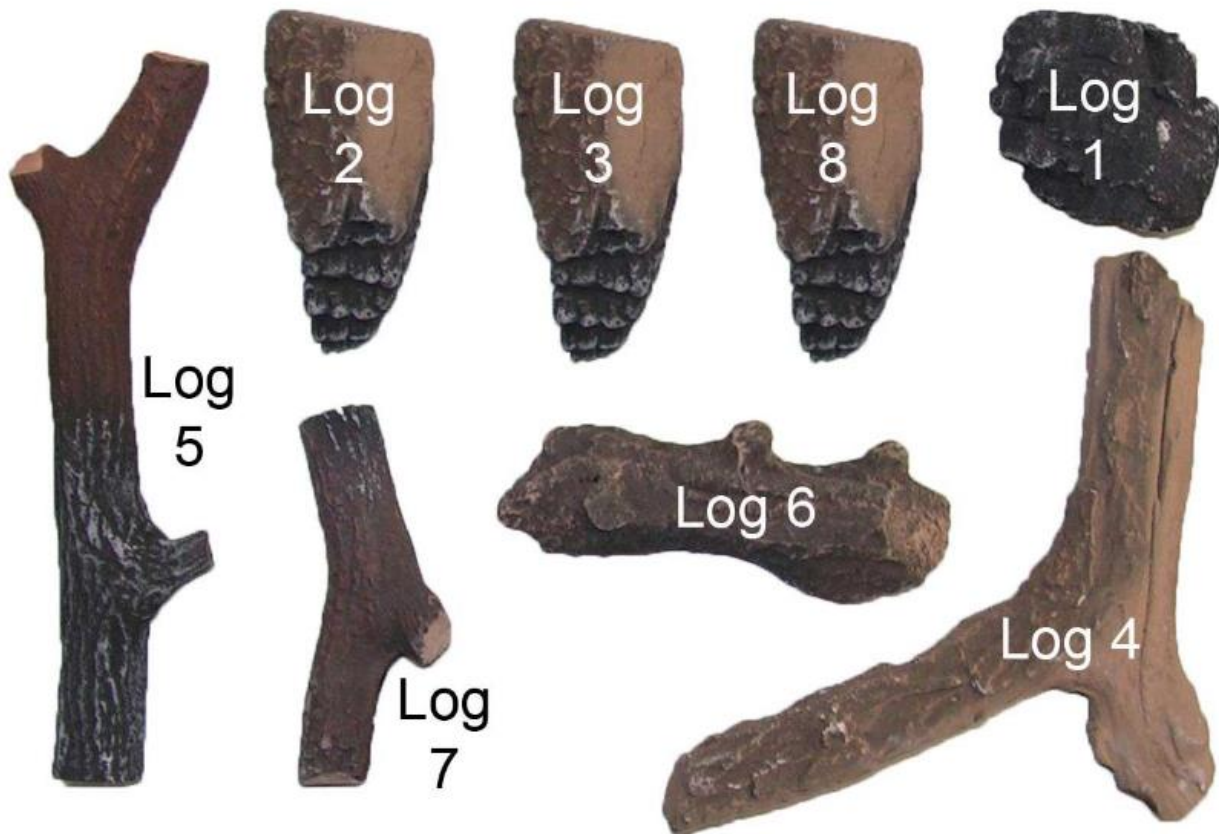

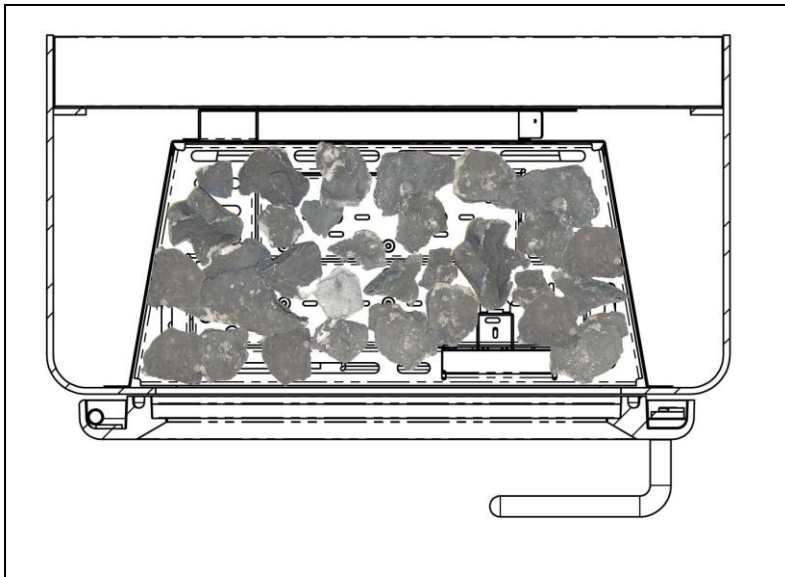

Scatter the Bags of Embers over the top of the burners as shown, keeping the pilot area clear.

Position the 6 logs as shown.

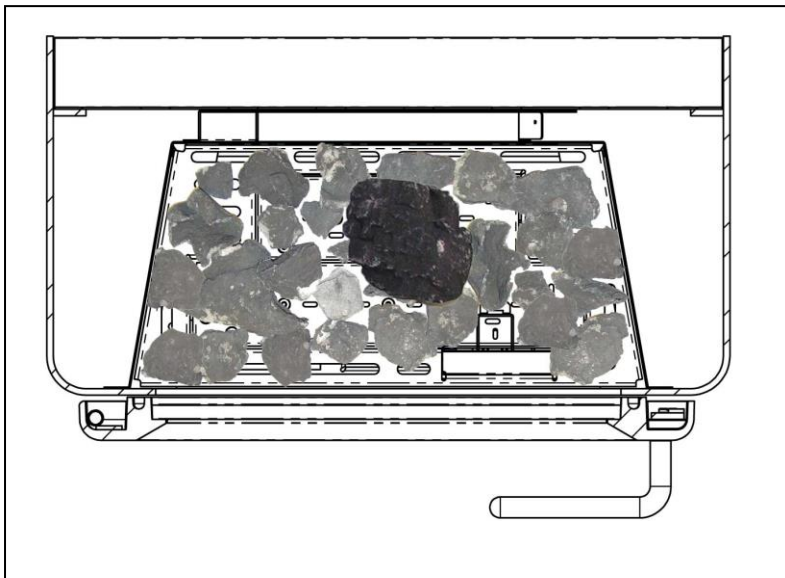

Log 1

Position Log 1 Centrally on the Burner, behind the central ports on the Front Burner.

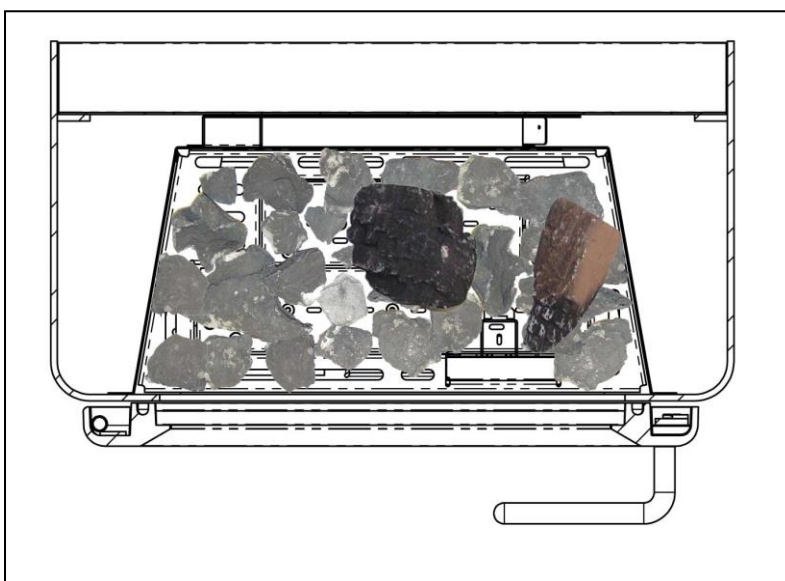

Log 2

Position Log 2 on top of the Right Hand side of the Front Burner, clearly to the Left of the Pilot.

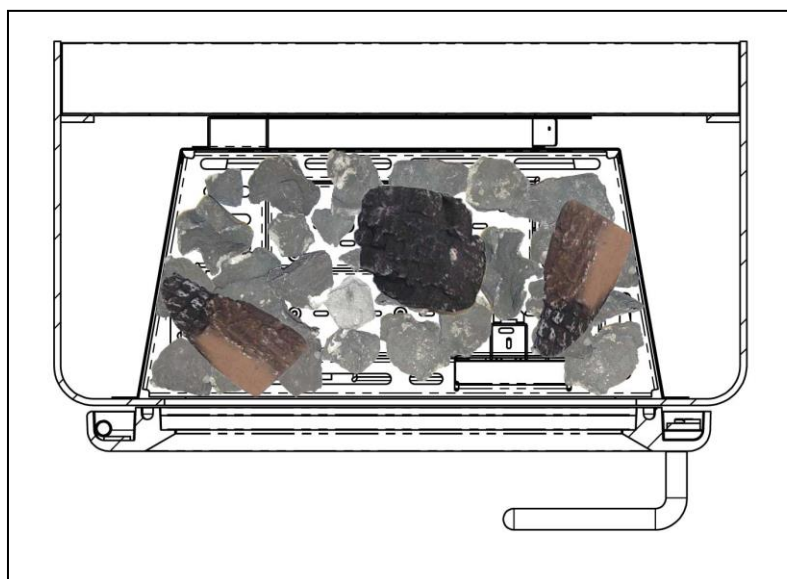

Log 3

Position Log 3 on top of the Left Hand side of the Front Burner

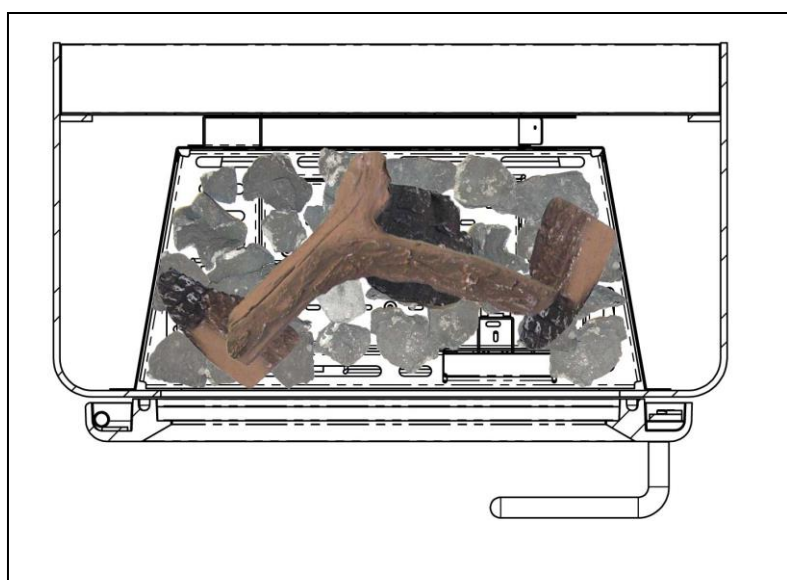

Log 4

Position Logs 4 so that it sits on top of Logs 1, 2 and 3

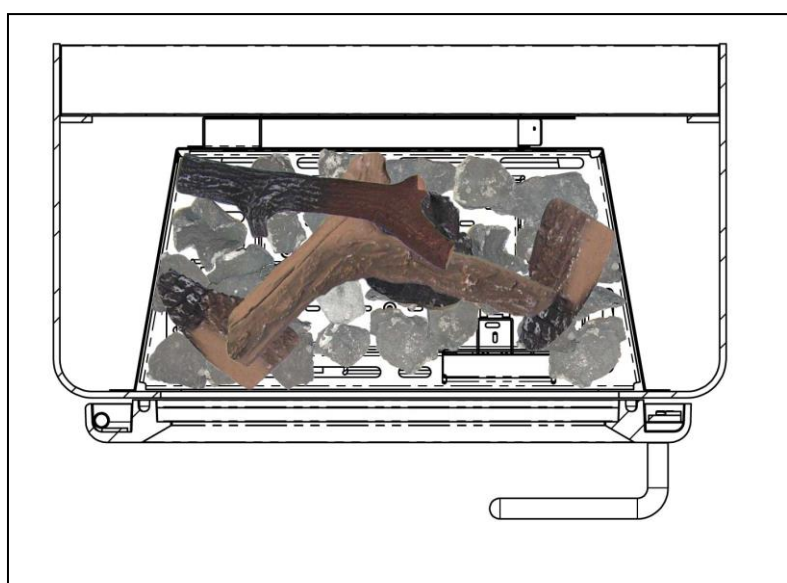

Log 5

Position Logs 5 so that it sits on top of Log 4 in the centre, with the bottom in the Left Hand Rear corner of the Fire Box

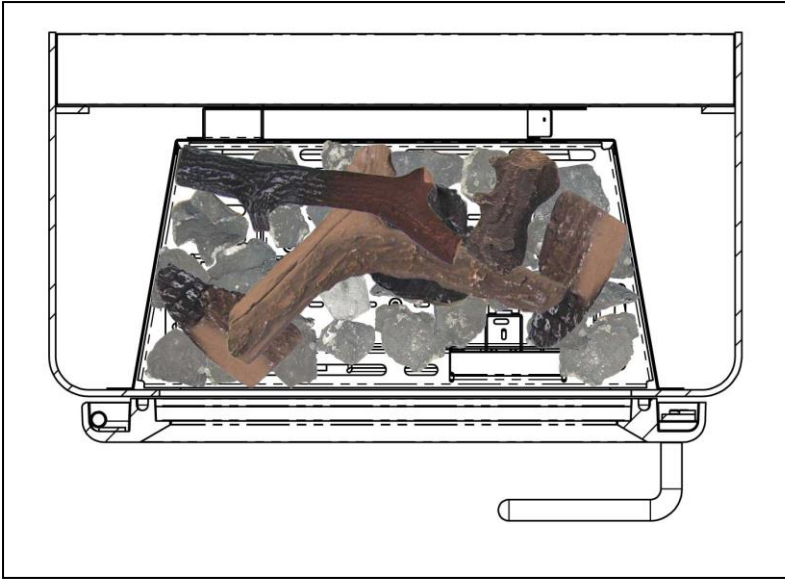

Log 6

Position Log 6 so that the Top of the Log sits on Log 4, with the bottom extending to the Rear of the Fire Box.

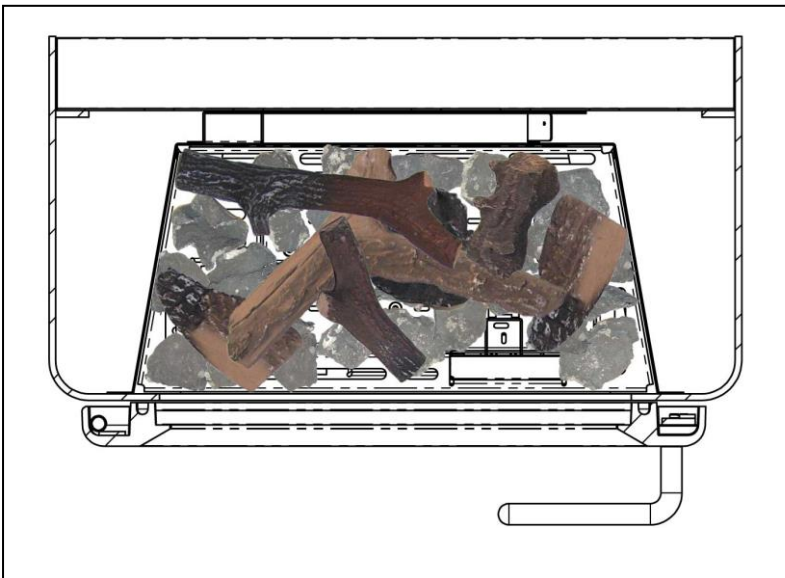

Log 7

Position Log 7 in the centre , sitting on the Grate, behind the Log Bar, with the Top on

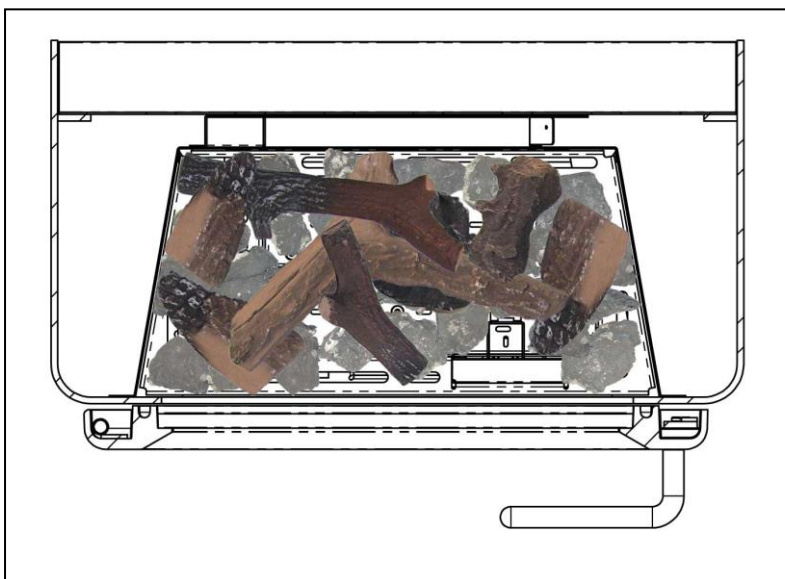

Log 8

Position Log 8 in the Left Hand Rear Corner, resting on Log 5

3.6 Commissioning the Appliance

3.6.1 Pilot Ignition Check

1. Ignite the pilot light as described in the User Instructions
2. Check that the pilot flame stays alight
3. Extinguish the pilot light

3.6.2 Main Burner Check

1. Ignite the pilot light as described in the User Instructions
2. Turn on the main burner as described in the User Instructions
3. Check that the pilot smoothly cross-lights to the main burner and that the main burner and pilot stay alight
4. Check the operation of the "effect" burners as described in the User Instructions
5. Extinguish the appliance fully

3.6.3 Pressure Check

The appliance is preset to give the correct heat inputs as listed in the technical details. No further adjustment is necessary. Always check the inlet pressure and burner pressure.

1. Turn off the gas valve on the appliance
2. Release the screw on the Inlet Pressure test point on the gas valve and connect a manometer
3. Check that the measured pressure is as the prescribed supply pressure
4. Perform the test when the appliance is burning on full (inc. "effect" burners) and with only the pilot alight
5. If the pressure is low, check the gas supply pipes are too a correct sizing
6. If the pressure is too high (more than 5 mbar over) the appliance may be installed, but the gas supply company should be contacted
7. Release the screw on the Burner Pressure test point on the gas valve and connect a manometer
8. Check that the measured pressure is as detailed in the Technical details
9. The measured value should be within +/- 10% of the described value. If this is not the case, please contact the supplier.

Note: After checking the pressures and removing the manometers, the screws in the Pressure Test points must be closed, and the system must be checked for gas-tightness.

4. Servicing

Turn the appliance OFF and isolate the gas supply. Ensure the appliance is fully cold before attempting to start servicing the appliance. No liability can be accepted by Mendip for injury caused by burning or scolding by a hot appliance.

A suggested procedure for servicing is listed below.

- A. Lay out dust sheet on flooring, mask off any special fireplace materials.
- B. Remove the door Lock.
- C. Open the Front Door Assembly.
- D. Carefully remove the Ceramic components (including Embers).
- E. Use a Vacuum cleaner to clean the top of the burners and grate
- F. Remove Grate
- G. Using a vacuum cleaner, fully clean the Burner.
- H. Use the vacuum cleaner and a soft brush to clean the pilot assembly and Injectors. Never modify or bend the Thermocouple
- I. Turn on the gas supply and check for leaks, check the burners and Pilot for good condition and operation
- J. Replace Grate
- K. Replace the Firebed arrangements
- L. Replace Window Assembly and Frame
- M. Check the flue system and terminal, making sure that the terminal vent is fully clear
- N. Light the appliance and test setting pressures
- O. Check the safe operation of the appliance.

4.1 Cleaning the Ceramics

Remove the ceramics as detailed in A - D above.

Gently clean the ceramics in the open air, using a soft brush and a vacuum cleaner. Where necessary replace damaged components only with genuine Mendip specified parts. Seal any scrap ceramics in plastic bags and dispose at proper refuse sites. When using a vacuum cleaner, it is recommended that one with a HEPA filtering system is used.

Re-fit the Firebed arrangement, re-seal the appliance and check the safe operation of the appliance.

4.2 Servicing the Burners

Remove the Ceramics as detailed in A - D above.

The pilot is now clearly visible, the pilot, including the Thermocouple, can be replaced/serviced by removing fully the pilot assembly from its mounting. This is done by removing the two screws on the surface of the pilot. The fittings on the under-side of the pilot can be un-done using a 10mm spanner where appropriate.

To access the Main Burner Injectors, the Burner base units must be removed. This is done by removing the four bolts (M6, 10mm spanner) holding the burner in. With these bolts removed, the Burner base can be passed up through the Firebox, and the Injectors can be easily accessed.

When replacing any parts use only original Mendip specified parts.

4.3 Spare parts

Item	ASHCOTT
Front Window Panel	M10560-01-01-99-00
Ceramic Log Pack	xxxxxxxx
Ember Pack	xxxxxxxx
Pilot Assembly Natural	G30-ZP2-312
Pilot Assembly LPG	G30-ZP2-271
Electrode	G30-SPK1
Electrode Lead	G60-ZKIS1 / 1500
Thermocouple	CG30182
Injector Natural Front (xxx)	xxxxxxxx
Injector Natural Rear (xxx)	xxxxxxxx
Injector LPG Front (xxx)	xxxxxxxx
Injector LPG Rear (xxx)	xxxxxxxx
Burner Top Assembly Front	xxxxxxxx
Burner Top Assembly Front	xxxxxxxx
Burner Elevated Assembly Right	xxxxxxxx
Complete Burner Assembly Natural	xxxxxxxx
Complete Burner Assembly LPG	xxxxxxxx
Burner Seal Set	xxxxxxxx
Grate Assembly	xxxxxxxx
Gas Valve Assembly Natural	xxxxxxxx
Gas Valve Assembly LPG	xxxxxxxx
Latching Solenoid	GV-S60C / 12
Receiver unit	G6R-R4AS
Handset	G6R-H4D

5. Technical Information

5.1 Countries of Use

Country	Natural	LPG
AT -Austria	I _{2H} , G20 at 20 mbar	I _{3P(50)} ,G31 at 50 mbar; I _{3B/P(50)} ,G30/G31 at 50 mbar
BE -Belgium	I _{2E+} , G20/G25 at 20/25 mbar	I ₃₊ ,G31/G31 at 28/37 mbar; I _{3P(37)} ,G31 at 37 mbar; I _{3B/P(30)} ,G30/G31 at 30 mbar
BG -Bulgaria	I _{2H} , G20 at 20 mbar	I _{3B/P(30)} ,G30/G31 at 30 mbar
CH - Switzerland	I _{2H} , G20 at 20 mbar	I _{3P(50)} ,G31 at 50 mbar; I ₃₊ ,G31/G31 at 28/37 mbar; I _{3P(37)} ,G31 at 37 mbar; I _{3B/P(50)} ,G30/G31 at 50
CY -Cyprus	I _{2H} , G20 at 20 mbar	I ₃₊ ,G31/G31 at 28/37 mbar; I _{3B/P(30)} ,G30/G31 at 30 mbar
CZ -Czech Republic	I _{2H} , G20 at 20 mbar	I _{3P(50)} ,G31 at 50 mbar; I ₃₊ ,G31/G31 at 28/37 mbar; I _{3P(37)} ,G31 at 37 mbar; I _{3B/P(50)} ,G30/G31 at 50
DE -Germany	I _{2ELL} , G25 at 20 mbar ¹ ; I _{2E} , G20 at 20 mbar	I _{3P(50)} ,G31 at 50 mbar; I _{3B/P(50)} ,G30/G31 at 50
DK -Denmark	I _{2H} , G20 at 20 mbar	I _{3B/P(30)} ,G30/G31 at 30 mbar
EE -Estonia	I _{2H} , G20 at 20 mbar	I _{3B/P(30)} ,G30/G31 at 30 mbar
ES -Spain	I _{2H} , G20 at 20 mbar	I ₃₊ ,G31/G31 at 28/37 mbar; I _{3P(37)} ,G31 at 37 mbar
FI -Finland	I _{2H} , G20 at 20 mbar	I _{3P(30)} ,G31 at 30 mbar; I _{3B/P(30)} ,G30/G31 at 30 mbar
FR -France	I _{2E+} , G20/G25 at 20/25 mbar	I ₃₊ ,G31/G31 at 28/37 mbar; I _{3P(37)} ,G31 at 37 mbar; I _{3B/P(30)} ,G30/G31 at 30 mbar; I _{3B/P(50)} ,G30/G31 at 50
GB -United Kingdom	I _{2H} , G20 at 20 mbar	I ₃₊ ,G31/G31 at 28/37 mbar; I _{3P(37)} ,G31 at 37 mbar; I _{3B/P(30)} ,G30/G31 at 30 mbar
GR -Greece	I _{2H} , G20 at 20 mbar	I ₃₊ ,G31/G31 at 28/37 mbar; I _{3P(37)} ,G31 at 37 mbar; I _{3B/P(30)} ,G30/G31 at 30 mbar
HU -Hungary		I _{3B/P(30)} ,G30/G31 at 30 mbar
HR -Croatia	I _{2H} , G20 at 20 mbar	I _{3P(37)} ,G31 at 37 mbar; I _{3B/P(30)} ,G30/G31 at 30 mbar
IE -Ireland	I _{2H} , G20 at 20 mbar	I ₃₊ ,G31/G31 at 28/37 mbar; I _{3P(37)} ,G31 at 37 mbar
IS -Iceland		
IT -Italy	I _{2H} , G20 at 20 mbar	I ₃₊ ,G31/G31 at 28/37 mbar; I _{3P(37)} ,G31 at 37 mbar; I _{3B/P(30)} ,G30/G31 at 30 mbar
LT -Lithuania	I _{2H} , G20 at 20 mbar	I ₃₊ ,G31/G31 at 28/37 mbar; I _{3P(37)} ,G31 at 37 mbar; I _{3B/P(30)} ,G30/G31 at 30 mbar
LU -Luxembourg	I _{2E} , G20 at 20 mbar	
LV -Latvia	I _{2H} , G20 at 20 mbar	
MT -Malta		I _{3B/P(30)} ,G30/G31 at 30 mbar
NL -The Netherlands	I _{2L} , G25 at 25 mbar I _{2EK} , G25.3 at 25 mbar I _{2(43.46 -45.3 MJ/m3 (0°C))} , G25.3 at 25 mbar	I _{3P(50)} ,G31 at 50 mbar; I _{3P(30)} ,G31 at 30 mbar; I _{3P(37)} ,G31 at 37 mbar; I _{3B/P(30)} ,G30/G31 at 30 mbar
NO -Norway	I _{2H} , G20 at 20 mbar	I _{3B/P(30)} ,G30/G31 at 30 mbar
PL -Poland	I _{2E} , G20 at 20 mbar	I _{3P(37)} ,G31 at 37 mbar
PT -Portugal	I _{2H} , G20 at 20 mbar	I ₃₊ ,G31/G31 at 28/37 mbar; I _{3P(37)} ,G31 at 37 mbar
RO -Romania	I _{2E} , G20 at 20 mbar	I _{3P(30)} ,G31 at 30 mbar; I _{3B/P(30)} ,G30/G31 at 30 mbar
SE - Sweden	I _{2H} , G20 at 20 mbar	I _{3B/P(30)} ,G30/G31 at 30 mbar
SL -Slovenia	I _{2H} , G20 at 20 mbar	I ₃₊ ,G31/G31 at 28/37 mbar; I _{3P(37)} ,G31 at 37 mbar; I _{3B/P(30)} ,G30/G31 at 30 mbar
SK -Slovakia	I _{2H} , G20 at 20 mbar	I _{3P(50)} ,G31 at 50 mbar; I ₃₊ ,G31/G31 at 28/37 mbar; I _{3P(37)} ,G31 at 37 mbar; I _{3B/P(30)} ,G30/G31 at 30 mbar; I _{3B/P(50)} ,G30/G31 at 50
TR -Turkey	I _{2H} , G20 at 20 mbar	I ₃₊ ,G31/G31 at 28/37 mbar; I _{3P(37)} ,G31 at 37 mbar; I _{3B/P(30)} ,G30/G31 at 30 mbar

5.2 Technical Data

Product Identification Number : 0359CT4093

5.2.1 Ashcott BF

Balanced Flue Ashcott Gas type		G20 l2H,l2E	G20/G25 l2E+	G25/G25.3 l2L/ l2EK l2(43.46 -45.3 MJ/m3 (0°C))	G20/G25 l2ELL
Supply Pressure	mbar	20	20 / 25	25	20
Nominal Heat Input Gross (Hs)	kW	9.5	9.5/ 8.8	8.8	8.3
Nominal Heat Input Nett (Hi)	kW	8.7	8.7 / 8	8	7.6
Consumption	m ³ /hr	0.89	0.89/ 0.95	0.95	0.89
Burner Pressure (hot)	mbar	19	11/ 24	24	19
Injector Marking		320 Front, 280 Back			
Pilot		G30-ZP2-312 (31.2 inj)			
Efficiency Class		1			
Nox Class		5			
Type		C11 / C31/ C91			

Gas type		G30/G31 l3B/P(30)	G30/G31 l3+	G31 l3P(50)	G31 l3P(37)	G31 l3P(30)
Supply Pressure	mbar	29	30 / 37	50	37	30
Nominal Heat Input Gross (Hs)	kW	10.5	10.5	10.5	10.5	8.8
Nominal Heat Input Nett (Hi)	kW	9.7	9.7	9.7	9.7	8.1
Consumption	m ³ /hr	0.271	0.271 / 0.37	0.37	0.37	0.3
Burner Pressure (hot)	mbar	27	27 / 36	36	36	28
Injector Marking		120 Front, 80 Back				
Pilot		G30-ZP2-271 (27.1 inj)				
Efficiency Class		1				
Nox Class		5				
Type		C11 / C31 / C91				

This product has been tested, and certified for use on Biopropane Gas.
Biopropane Gas can be used as a fuel, with no adjustment necessary if the product is installed as an LPG version.

5.3 Dimensions

5.3.1 Ashcott Top Flue

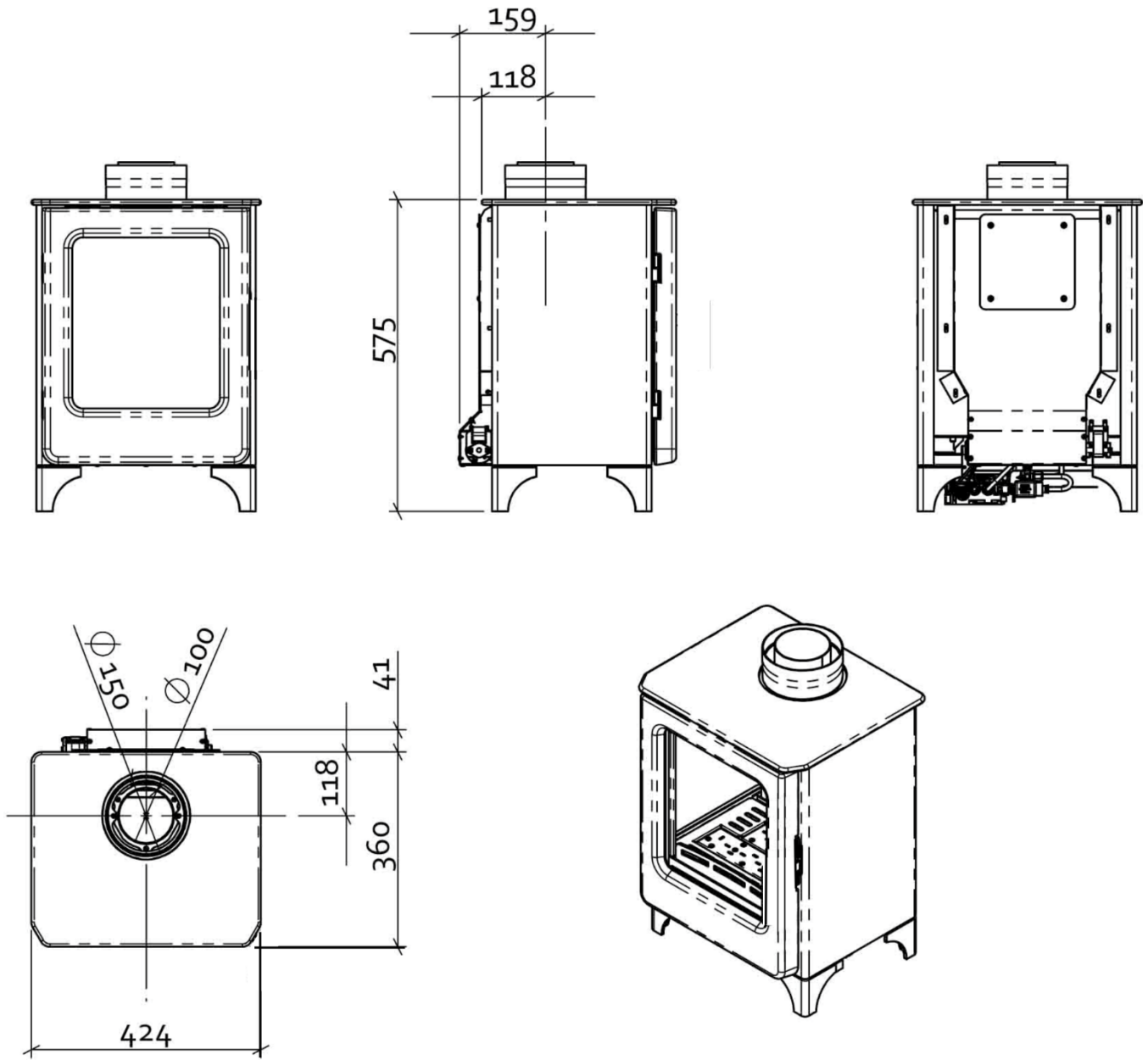

5.3.2 Ashcott Rear Flue

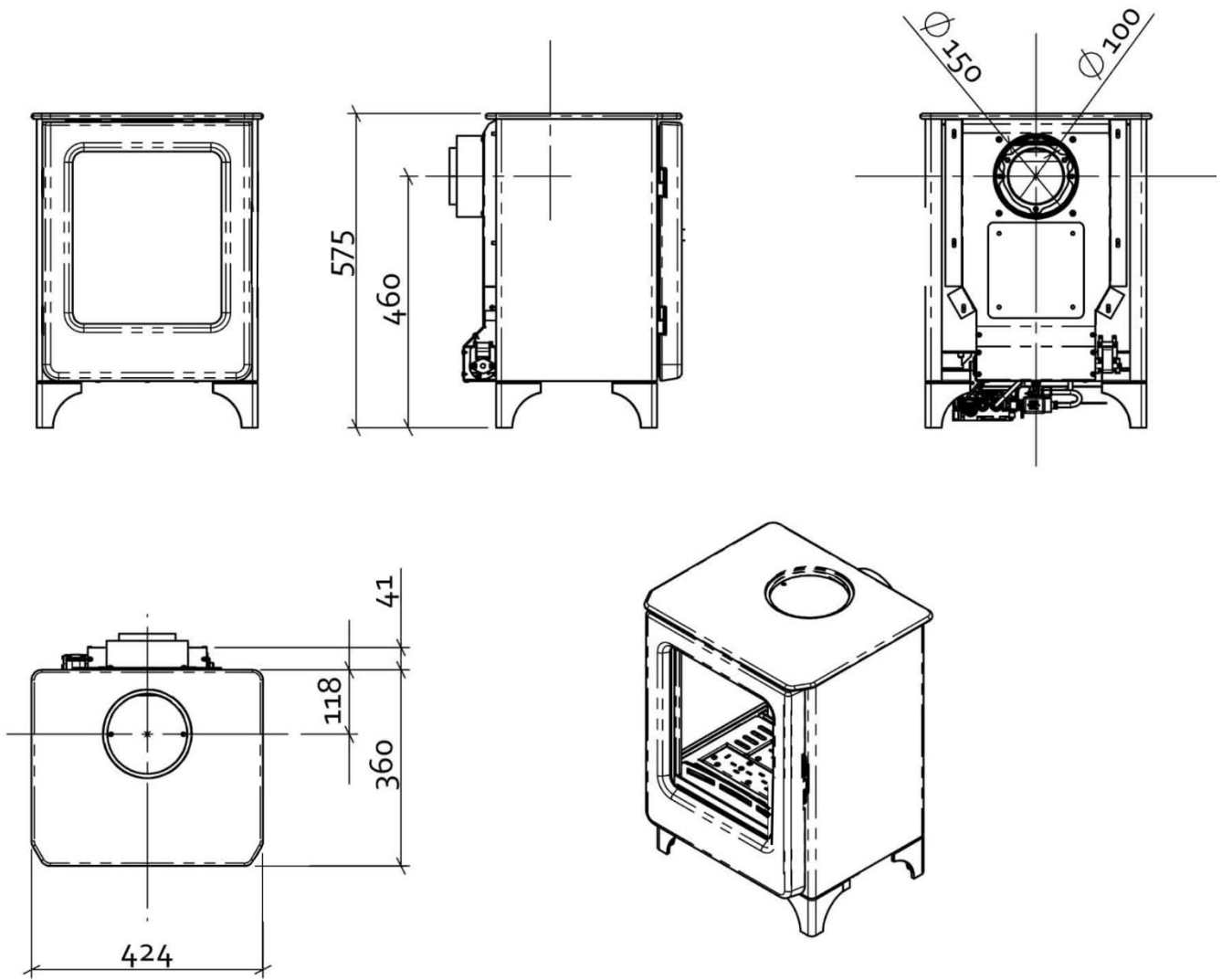

Appendix 1 - Mertik Maxitrol Symax Control System.

Fitting batteries into the receiver box



Fig 1

Ensure fire is turned off

Open door

Remove steel cover plate by unscrewing the cross head screws. Fig 1

Behind the plate to the left is the receiver box. This receiver box takes 4 x AA batteries. Fig 2



Fig 2

Slide back battery cover plate. Fig 4

Place batteries in place making sure red ribbon is held across battery area before placing in batteries, Place batteries on order shown in Fig 3

Placing the ribbon across battery store will help the removal of batteries in future.

Battery order Positions Furthest away from door



Fig 3

Battery 1 Plus to right

Battery 2 Plus to Left

Battery 3 Plus to Right

Battery 4 Plus to Left

Closest to door



Fig 4

Slide open cover plate put in batteries

Slide battery cover back over receiver box

Refit cover plate, Batteries should be replaced annually.



MENDIP STOVES

Unit H1

Mendip Industrial Estate

Mendip Road

Rooksbridge

Somerset

BS26 2UG

Tel. : +44 (0) **1934 750500**

Web : www.mendipstoves.co.uk

Email : info@eurostove.co.uk



Mendip stoves: Ashcott BF GAS manual mar 2020. V1.5b