



Neo

Multifuel Stove • Model Neo 1 / Neo 3

To be retained by the user for future reference

Thank you for purchasing an ACR Heat Products stove



Serial Number:

Document NEO • Version 3 Date 08/07/15

T
E
C
H
N
I
C
A
L
M
A
N
U
A
L

Important!

To ensure that you gain the most from your purchase, please take a few minutes to read through this manual before lighting the appliance for the first time.

Since April 2002 only registered competent installers can install solid fuel appliances. Installations carried out by non-registered installers must be inspected by local authority building control.

For more information please contact hetas at: www.hetas.co.uk or telephone: 0845 6345626

- The installation of this appliance must comply with current Building Regulations and local regulations, including those referring to national and European standards need to be complied with when installing the appliance.
- Do not operate this appliance if it becomes damaged.
- Improper use, maintenance or fitting parts other than those approved by the manufacturer could lead to the appliance becoming damaged or unsafe which in turn could lead to personal injury or damage to the property and will void the warranty.
- The appliance must not be modified in anyway unless authorised by ACR Heat Products Ltd.
- The appliance should be inspected regularly to ensure the airways are clean and free from obstruction and the chimney swept at least once a year.
- The external surfaces of this appliance will be very hot to the touch when in operation and due care will need to be taken when operating the appliance to ensure safety. A fire guard should be fitted if it is likely that the elderly, infirm or children may come into contact with the appliance.
- This appliance must not be used as an incinerator.
- This appliance has been designed for intermittent operation.

Before installation, please ensure that the correct model has been supplied.

Please make a note of the serial number of your appliance in the space provided on the front cover of this manual as this will be requested if you require technical assistance in the future.

Please also ensure that the commissioning checklist at the rear of the manual is completed in full.

The Clean Air Act 1993 and Smoke Control Areas

Under the Clean Air Act local authorities may declare the whole or part of the district of the authority to be a smoke control area. It is an offence to emit smoke from a chimney of a building, from a furnace or from any fixed boiler if located in a designated smoke control area. It is also an offence to acquire an "unauthorised fuel" for use within a smoke control area unless it is used in an "exempt" appliance ("exempted" from the controls which generally apply in the smoke control area).

The Secretary of State for Environment, Food and Rural Affairs has powers under the Act to authorise smokeless fuels or exempt appliances for use in smoke control areas in England. In Scotland and Wales this power rests with Ministers in the devolved administrations for those countries. Separate legislation, the Clean Air (Northern Ireland) Order 1981, applies in Northern Ireland. Therefore it is a requirement that fuels burnt or obtained for use in smoke control areas have been "authorised" in Regulations and

that appliances used to burn solid fuel in those areas (other than "authorised" fuels) have been exempted by an Order made and signed by the Secretary of State or Minister in the devolved administrations.

- **The Neo range (Neo 1P, Neo 1C, Neo 1W, Neo 3P, Neo 3C, Neo 3W, Neo 1F & Neo 3F) has been recommended as suitable for use in smoke control areas when burning wood, as such, when the air control wheel is in the closed position it remains open by 27mm and is prevented from closing by a screw.**



Further information on the requirements of the Clean Air Act can be found here: <http://smokecontrol.defra.gov.uk>

Your local authority is responsible for implementing the Clean Air Act 1993 including designation and supervision of smoke control areas and you can contact them for details of Clean Air Act requirements.

CO Alarms

It is required by building regulations that whenever a new or replacement wood/solid fuel or biomass appliance is installed in a dwelling a carbon monoxide alarm to BS EN 50292:2002 must be fitted in the same room as the appliance.

The alarm should be installed according to the alarms manufacturers instructions and should not be considered a substitute for the appliance being installed correctly and regular maintenance of the appliance and flue system by a competent person.

Neo Specifications

Neo 1C / 3C

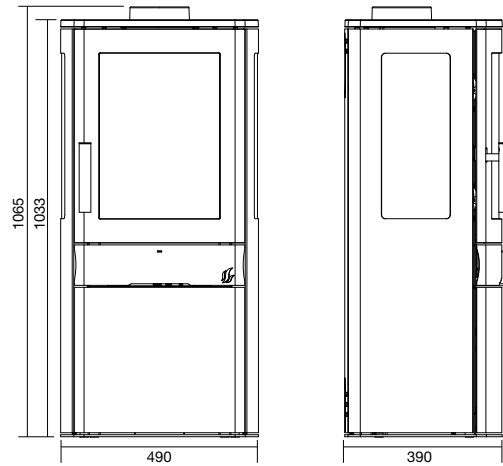

Fuel	Wood with Solid Fuel Option
Nominal Output	5 kw
Net Efficiency	81.8%
Gross Efficiency	74.4%
Max Hearth Temp	Less than 100°C
Weight	110 kg
Max Log Size	40 cm
Flue Diameter	125 mm (inside dia)
Flue Location	Top or Rear
Floor to centre of rear flue outlet	920 mm
Rear of stove to centre top flue outlet	145 mm
Construction	Cast Iron and Steel

Neo 1W / 3W

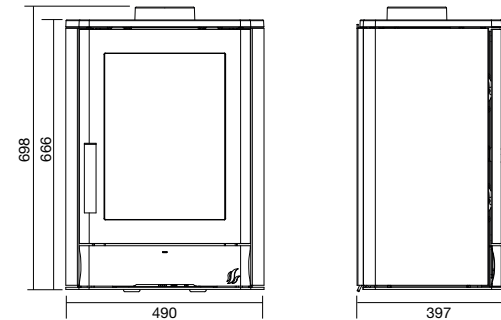

Fuel	Wood with Solid Fuel Option
Nominal Output	5 kw
Net Efficiency	81.8%
Gross Efficiency	74.4%
Max Hearth Temp	Less than 100°C
Weight	90 kg
Max Log Size	40 cm
Flue Diameter	125 mm (inside dia)
Flue Location	Top or Rear
Base of stove to centre of rear flue outlet	556 mm
Rear of stove to centre top flue outlet	145 mm
Construction	Cast Iron and Steel

Neo 1P / 3P

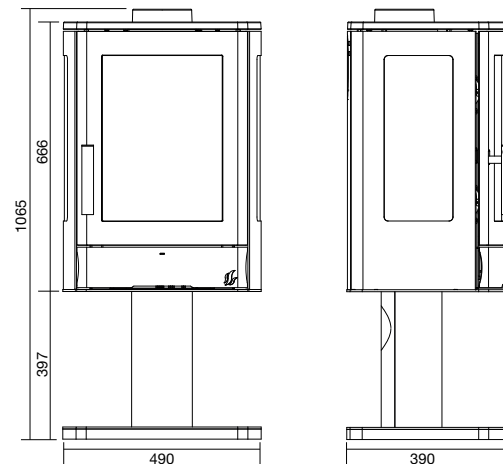

Fuel	Wood with Solid Fuel Option
Nominal Output	5 kw
Net Efficiency	81.8%
Gross Efficiency	74.4%
Max Hearth Temp	Less than 100°C
Weight	105 kg
Max Log Size	40 cm
Flue Diameter	125 mm (inside dia)
Flue Location	Top or Rear
Floor to centre of rear flue outlet	920 mm
Rear of stove to centre top flue outlet	145 mm
Construction	Cast Iron and Steel

Neo 1F / 3F

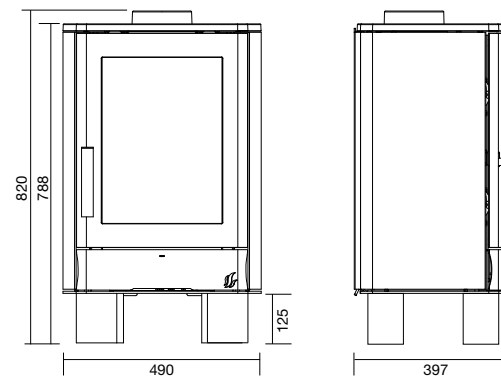

Fuel	Wood with Solid Fuel Option
Nominal Output	5 kw
Net Efficiency	81.8%
Gross Efficiency	74.4%
Max Hearth Temp	Less than 100°C
Weight	90 kg
Max Log Size	40 cm
Flue Diameter	125 mm (inside dia)
Flue Location	Top or Rear
Floor to centre of rear flue outlet	675 mm
Rear of stove to centre top flue outlet	145 mm
Construction	Cast Iron and Steel

Neo Specifications

	Neo 1P-1C/ Neo 3P-3C Wood Logs	Neo 1P-1C/ Neo 3P-3C Smokeless Fuel	Neo1W/ Neo 3W Wood Logs	Neo1W/ Neo 3W Smokeless Fuel	Neo1F/ Neo 3F Wood Logs	Neo1F/ Neo 3F Smokeless Fuel
Chimney draft required	12Pa	12Pa	12Pa	12Pa	12Pa	12Pa
Air Requirement	N/A ***	N/A ***	N/A ***	N/A ***	N/A ***	N/A ***
Flue Mass Gas Flow	5.1g/s	6g/s	5.1g/s	6g/s	5.1g/s	6g/s
CO @ 13% O ²	0.58 vol %	0.38 vol %	0.58 vol %	0.38 vol %	0.58 vol %	0.38 vol %
Mean Flue Gas Temperature	166°C	207°C	166°C	207°C	166°C	207°C
Efficiency	81.8%	75.7%	81.8%	75.7%	81.8%	75.7%

***Please note that Building Regulations Document J advises that additional permanent air supply is required for appliances with an output of above 5Kw.

With modern properties additional air may be required as Document J suggests that adequate air would be a benefit.

- If design air permeability $\geq 5.0\text{m}^3/(\text{h}\cdot\text{m}^2)$ then 550mm²/kW of appliance rated output above 5kW

Or

- If design air permeability $\leq 5.0\text{m}^3/(\text{h}\cdot\text{m}^2)$ then 550mm²/kW of appliance rated output
- If in doubt, please consult your registered installer for advice.

NOTE: DO NOT INSTALL IN A ROOM CONTAINING AN EXTRACTOR FAN



Installation Instructions

Location of the unit

Clearances to non-combustible materials

• Neo 1P/1C/3P/3C/1F/3F

There is a recommended minimum clearance of 150mm at each side of the appliance. A clearance of 150mm is required at the back of stove (if the rear wall has a thickness of 200mm or more this measurement can be reduced to 50mm) a minimum clearance of 300mm is required above the appliance.

• Neo 1W/3W

There must be a minimum clearance of 150mm at each side of the appliance. The wall behind the appliance must be a minimum thickness of 200mm and be able to bear the weight of the appliance. The wall must consist of, or be insulated with, fire proof materials. The insulation material must resist a temperature of 700°C and have a density of 80 Kg/m³, such as Vitcas fireplace render and Vitcas Heat Resistant plaster (www.vitcas.com)

Avoid heat transmission when placing the stove. Heat transmission of a burning stove can penetrate the wall and even cause fire damage on the other side of the wall. Prevention is better than cure.

Clearances to combustible materials

• Neo 1P/1C/3P/3C/1F/3F

For the 1P/1C models there must be a minimum clearance of 300mm at each side of the appliance, for the 3P/3C models there must be a minimum clearance of 500mm at each side of the appliance, all models require a 300mm clearance at the rear of the appliance from any combustible materials. If using single wall flue pipe, there must be a clearance of at least 3 times the diameter

of the flue pipe (e.g. 125mm diameter pipe = 375mm minimum clearance) from any combustible materials e.g. wooden beam.

• Neo 1W/3W

There must be a minimum clearance of 500mm at each side and 300mm at the rear of the appliance from any combustible materials. If using single wall flue pipe, there must be a clearance of at least 3 times the diameter of the flue pipe (e.g. 125mm diameter pipe = 375mm minimum clearance) from any combustible materials e.g. wooden beam.

Curtains and soft furnishings should be a minimum of 1m away from the appliance.

Adequate space should be provided for servicing the appliance.

We do not recommend that plasma televisions and expensive artwork are hung over the fireplace.

Please remember that this appliance has been designed to provide heat and if installed into a recess enough space should be left around the appliance to enable the heat produced to rise and escape from the recess back into the room.

Hearth Requirements

The appliance must stand on a level fireproof hearth with a minimum thickness of 12mm. The hearth temperature created by this stove is below 100°C. The hearth must protrude at least 300mm in front of the appliance and 150mm either side of the appliance.

The appliance shall be installed on a floor with an adequate load bearing capacity. If an existing construction doesn't meet with prerequisite, suitable measures (e.g. load distributing plate) shall be taken to achieve it.

Installation Instructions

Flue Requirements

The chimney must comply with current Building Regulations. Provision must be made to provide access for cleaning the appliance, the flue gas connector and the chimney flue.

flue system without removal of the appliance

- ✓ Free from deposits
- ✓ Well insulated
- ✓ At least 4.5m in height

The flue must be:

- ✓ In sound condition and provide sufficient draft (minimum 12 Pa)
- ✓ Suitable for use with solid fuel burning appliances
- ✓ Be able to clean the entire length of the

The flue must not be:

- ✗ Shared with other appliances
- ✗ Weight bearing on the appliance
- ✗ A smaller diameter than the appliance flue collar size (125mm)

Assembly of the unit

This appliance is equipped with a pre-fitted manufacturers smoke exempt stop. Under no circumstances should it be tampered with or removed unless expressly authorised by a competent person and the appliance is not installed in a smoke exempt area.

If the appliance is to be installed in a non smoke exempt area you can remove the restricting screw on the air control wheel to allow full movement.

The appliance is supplied pre-assembled with the flue spigot in the top exit position.

If you intend to install the appliance using a rear flue connection, the blanking plate should be swapped over as follows:

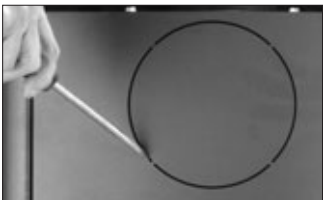

- Remove the outer blanking plate in the rear panel



- Remove the inner blanking plate by removing the two bolts

- Remove the flue spigot from the top exit by removing the securing bolts and rope seal
- Refit the rope seal and flue spigot to the rear exit and secure with the bolts.
- Refit the blanking plate to the top exit using the rope seal and retaining bolts.
- Insert cosmetic cast iron blanking plate into top casting recess

Installing the Neo 1W/3W

To install the Neo wall hung version firstly check the suitability of the wall where the appliance is to be mounted, paying particular attention to the Neo 1W/3W section on location of unit earlier in this manual.



- Fully unpack the appliance and remove the top casting plate



- Remove both cotter pins from the retaining bar

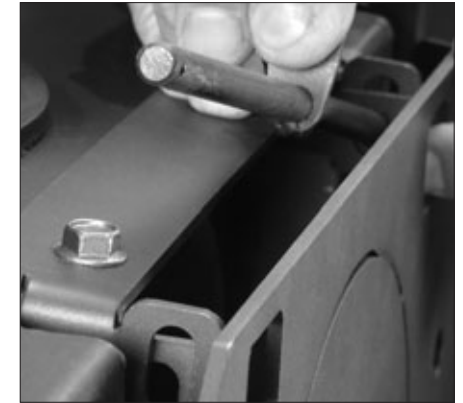

- Remove the retaining bar by sliding it in any direction and angling the bar upwards before sliding the bar fully out of the brackets
N.B. be careful to support the weight of the mounting bracket when removing the retaining bar



- Carefully tilt the mounting bracket away from the appliance at the top and remove from the bottom supporting hooks



- The minimum distance above the finished hearth level is 300mm
- Secure to the wall using a suitable heavy duty wall fixing which is applicable to the wall type and is also heat resistant
- Use a minimum of 6 fixing points to evenly spread the load



- Fully remove the mounting bracket from the appliance the bracket is now ready to be positioned against the wall
- Position mounting bracket against the wall, making sure that the bracket is perfectly level as this will affect the leveling of the appliance

- Once mounting bracket is securely fixed to wall position the bottom of the appliance on to the hooks at the bottom of the mounting bracket
- Tilt the appliance into the vertical position and replace the retaining bar and cotter pins as per previous instruction



Operating your stove

Please note that during the first firing, we recommend a small fire is lit and that you slowly increase the temperature to enable the various parts to expand normally.

You may also experience fumes and a haze being given off by the stove during the first firing and possibly for the next couple of firings as the paint cures. This is normal but please ensure that the room is well ventilated during this period.

The appliance should not be operated in mild weather with smokeless fuel. Under certain weather circumstances e.g. fog the chimney will not draw sufficiently and could cause asphyxiation. Await better weather conditions before attempting to use the appliance.

In the rare event of a malfunction due to overheating or a chimney fire, the air control should be shut down completely and the fuel allowed to burn out. In the event of a chimney fire, once the air control has been closed completely, dial 999 for assistance. If the appliance has overheated, the appliance and flue will need to be inspected for any damage before it can be operated again.

Recommended Fuels

✓ **Wood:** hardwood such as ash, oak and beech which have been cut for at least 2 years and stored under shelter. The logs should have a maximum moisture content of 20%. Maximum log length 400mm, maximum width 125mm.

✓ **Smokeless Fuels:** below 20% Petroleum coke content such as Anthracite, Phurnacite, Ancit suitable for use with a closed heating appliance.

Prohibited Fuels

✗ **Green wood:** i.e wood which is less than 2 years old with a moisture content of above 20%

✗ **Recovered wood:** i.e pallets, railway sleepers etc. These will have been chemically treated and will pollute the atmosphere and possibly overheat the appliance.

✗ **Housecoal or Bituminous coal:** these fuels will soot up the airways of the stove and possibly overheat the appliance.

✗ **Petroleum Based Coke:** over 20% - this will overheat the appliance and possibly damage the unit.

✗ **Liquid fuels.**

Always check with your dealer or directly with the manufacturer as using the incorrect fuel will invalidate your guarantee and damage your appliance.

Operating your stove

Instructions for use with wood

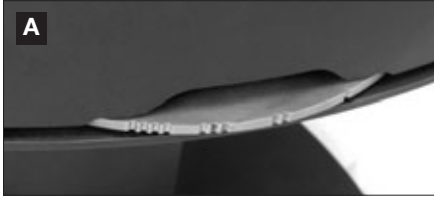

A Rotate the air control wheel fully to the right until the wheel stops, you should now have the four grooves central to the appliance door.

- Lay firelighters or rolled up newspapers on the grate and add a small amount of kindling wood to the top. Place 1 or 2 small logs on the top.
- Light the newspaper or firelighters using a long taper and push the door to but do not engage the locking mechanism fully.
- When the fire is burning fiercely, after a couple of minutes add more logs and close the door.

B When the fire has become established, rotate the air control to the left until the three grooves are central to the door.



C The burning rate can be altered by rotating the air control wheel between the three groove and the one groove setting - rotate the air control towards the left to decrease the burn rate and heat output

- Care should be taken to ensure that the logs are not placed higher than the log guard allows.

Instructions for use with smokeless fuel

A Rotate the air control wheel fully to the right until the wheel stops, you should now have the four grooves central to the appliance door.

- Lay firelighters or rolled up newspapers on the grate and add a small amount of kindling wood to the top. Place a small quantity of smokeless fuel on top
- Light the newspaper or firelighters using a long taper and push the door to but do not engage the locking mechanism fully
- When the fire is burning fiercely, after a couple of minutes add more smokeless fuel and close the door.

B When the fire has become established, rotate the air control to the left until the three grooves are central to the door.

C The burning rate can be altered by rotating the air control wheel between the four groove and the two groove setting - rotate the air towards the left to decrease the burn rate and heat output.



- Care should be taken to ensure that the firebox is not overfilled with smokeless fuel - it should be no higher than the log guard.

Operating your stove

Re-fueling

When refueling the stove **always refuel onto a bed of hot embers**, fully open the air control wheel to the right, indicated by the four grooves until the new fuel is well alight, before adjusting the air controls for the desired setting.

If there is insufficient burning material in the firebed to light a new fuel charge, excessive smoke emission can occur. Refueling must be carried out onto a sufficient quantity of glowing embers and ash that the new fuel charge will ignite in a reasonable period. If there are too few embers in the fire bed, add suitable kindling to prevent excessive smoke.

Ashpan removal

The Neo range is equipped with a slide out ash draw

To remove the ash pan, firstly pull out the ash pan draw. **Be careful this part of the appliance will be hot!** We recommended that you use the glove provided.

Using the ashpan cover and glove, lock the cover into place and lift the complete ashpan out and dispose of safely



Fuel overloading

Never overload the stove - it will work very well with two medium sized logs. The amount of fuel specified in this manual should not be exceeded, overloading can cause excess smoke.

Operation with door left open

Operation with the door open can cause excess smoke. The appliance must not be operated with the appliance door left open except as directed in the instructions.

Air controls left open

Operation with the air controls or appliance dampers open fully can cause damage to the appliance. The appliance must not be operated with air controls, appliance dampers or door left open except as directed in the instructions.

- **Never leave the stove unattended until the new fuel is well alight.**

Persistent fume emission is dangerous and must be investigated.

If fume emission persists, open doors and windows to ventilate the room and let the fire die. Have the chimney inspected for blockages and clean if required. Do not relight the fire until the cause has been found. We recommend that you seek professional advice.

This appliance has been designed to be burned with the door closed at all times other than when refueling.

It should not be operated as an open fire.

Typical refueling intervals for wood is 1 hour and smokeless fuel is 2 hours.

Daily Maintenance

The ashpan should be checked and emptied regularly. You should never allow the ashes in the pan to build up to the level of the grate. If they are allowed to build up, the grate will become sandwiched between the ash below it and above it. This will overheat the grate and cause distortion and premature wear.

Maintenance

We recommend that the appliance is serviced annually by a competent engineer to ensure it's continued safe operation.

The chimney should be swept at least once a year together with the flue pipe connection. Care should be taken to ensure that there is not a build up of soot on the baffle and in the airways of the appliance.

If the appliance has not been operated for long periods, the flue should be inspected and swept before use to ensure there are no blockages within the flue.

The grate should be cleaned regularly and the ashpan emptied daily.

The ash draw runners can be periodically lubricated with a high temperature lubricant such as graphite powder, to ensure their smooth running operation.

Never allow the ash in the ashpan to overflow allowing ash to be in contact with the underside of the grate.

This will overheat the grate and cause premature wear and distortion.

- The internal vermiculite panels of the appliance should be checked regularly for soundness. If any wear and tear is found, we recommend these parts are replaced immediately.
- Check the rope door seals are intact and are not worn. These should be replaced on an annual basis to ensure the correct operation of this appliance.
- The glass can be cleaned using a soft damp cloth or a ceramic glass cleaner (available from your local stockist)

Use only replacement parts recommended by the manufacturer.

Troubleshooting

Problem	Probable Cause	Action Recommend
Fire difficult to start / goes out	• Green wood / wet wood	Use hardwood logs with a maximum moisture content of 20%
	• Logs are too large	Use kindling and small logs to start the fire and once established use split logs
	• Not enough primary air	Open air control
	• Insufficient draft	Check the flue is not obstructed
Fire burns too quickly	• Too much draft	Reduce the air control
	• Excessive draft	Install a draft stabiliser
Smokes on initial lighting	• Flue is cold	Burn paper and kindling to increase heat in flue
Smokes while burning	• Insufficient draught	Check the flue is not obstructed
Low heat output	• Poor quality wood	Use seasoned Hardwood (this has a Higher calorific value)



Parts Information Neo 1C

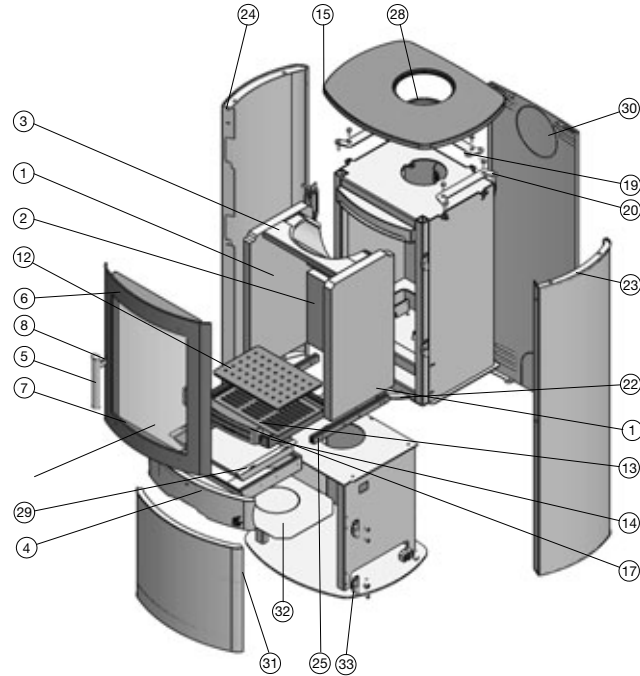

Diagram No.	Part No.	Description	Quantity Required
1	N4140002	Vermiculite side bricks	2
2	N41040003	Vermiculite rear brick	1
3	N41040004	Vermiculite baffle	1
4	N41033000	Sliding ash draw assembly	1
5	N41021000	Handle	1
6	N41020001	Cast iron door	1
7	N17015206	Glass clips	4
8	N41020002	Door handle bracket	1
N/A	N808-30-00	Door roller catch	2
N/A	N41041001	Inner blanking plate	1
N/A	N41041002	Ashpan lid	1
12	N41070003	Cast iron wood grate	1
13	N41070002	Cast iron solid fuel grate	1
14	N41070001	Cast iron grate support	1
15	N41060000	Cast iron top plate	1
16	N41045001	Front door glass	1
17	N41041015	Fuel retainer wood	1
N/A		Fuel retainer solid fuel	1
19	N41041014	Outer rear support bracket	1
20	N41041013	Outer side support brackets	2
N/A	N41041011	Baffle support bracket	1
22	N41041009	Control wheel	1
23	N41131000	Outer right panel	1
24	N41132000	Outer left panel	1
25		Ash draw runners	2
N/A		Door sealing gasket	1.7M
N/A		Glass sealing gasket	1.5M
28	N150-32	Cast iron collar	1
29	N41041002	Ashpan	1
30	N41037000	Outer Rear panel	1
31	N41034000	Cupboard door	1
32	N41041003	Heat Shield	1
33	N41039000	Cupboard hinge	2

Parts Information Neo 3C

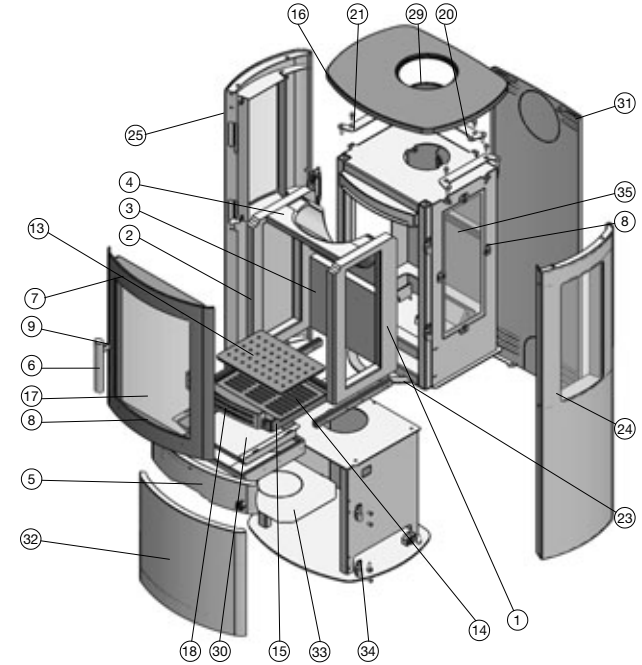

Diagram No.	Part No.	Description	Quantity Required
1	N41040001	Vermiculite right side brick	1
2	N41040002	Vermiculite left side brick	1
3	N41040003	Vermiculite rear brick	1
4	N41040004	Vermiculite baffle	1
5	N41033000	Sliding ash draw assembly	1
6	N41021000	Handle	1
7	N41020001	Cast iron door	1
8	N17015206	Glass clips	20
9	N41020002	Door handle bracket	1
N/A	N808-30-00	Door roller catch	2
N/A	N41041001	Inner blanking plate	1
N/A	N41041002	Ashpan lid	1
13	N41070003	Cast iron wood grate	1
14	N41070002	Cast iron solid fuel grate	1
15	N41070001	Cast iron grate support	1
16	N41060000	Cast iron top plate	1
17	N41045001	Front door glass	1
18	N41041015	Fuel retainer wood	1
N/A		Fuel retainer solid fuel	1
20	N41041014	Outer rear support bracket	1
21	N41041013	Outer side support brackets	2
N/A	N41041011	Baffle support bracket	1
23	N41041009	Control wheel	1
24	N41031000	Outer right panel	1
25	N41032000	Outer left panel	1
26		Ash draw runners	2
N/A		Door sealing gasket	1.7M
N/A		Glass sealing gasket	6.3M
29	N150-32	Cast iron collar	1
30	N41041002	Ashpan	1
31	N41037000	Outer Rear panel	1
32	N41034000	Cupboard door	1
33	N41041003	Heat Shield	1
34	N41039000	Cupboard hinge	2
35	N41045002	Inner side glass	2
36	N41045003	Outer side glass	2

Parts Information Neo 1P

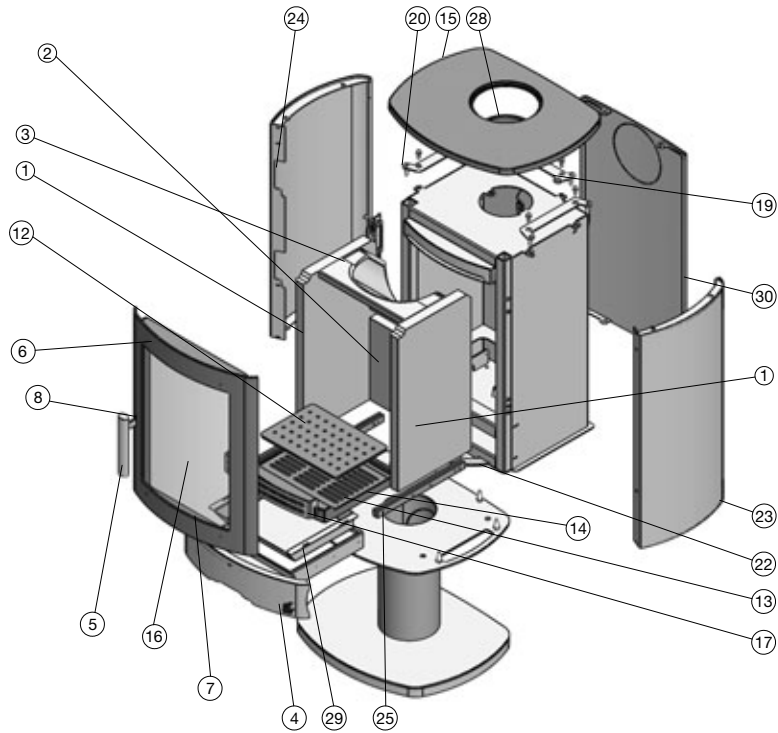

Diagram No.	Part No.	Description	Quantity Required
1	N4140002	Vermiculite side bricks	2
2	N41040003	Vermiculite rear brick	1
3	N41040004	Vermiculite baffle	1
4	N41033000	Sliding ash draw assembly	1
5	N41021000	Handle	1
6	N41020001	Cast iron door	1
7	N17015206	Glass clips	4
8	N41020002	Door handle bracket	1
N/A	N808-30-00	Door roller catch	2
N/A	N41041001	Inner blanking plate	1
N/A	N41041002	Ashpan lid	1
12	N41070003	Cast iron wood grate	1
13	N41070002	Cast iron solid fuel grate	1
14	N41070001	Cast iron grate support	1
15	N41060000	Cast iron top plate	1
16	N41045001	Front door glass	1
17	N41041015	Fuel retainer wood	1
N/A		Fuel retainer solid fuel	1
19	N41041014	Outer rear support bracket	1
20	N41041013	Outer side support brackets	2
21	N41041011	Baffle support bracket	1
22	N41041009	Control wheel	1
23	N41331000	Outer right panel	1
24	N41332000	Outer left panel	1
25		Ash draw runners	2
N/A		Door sealing gasket	1.7M
N/A		Glass sealing gasket	1.5M
28	N150-32	Cast iron collar	1
29	N41041002	Ashpan	1
30	N41237000	Outer Rear panel	1

Parts Information Neo 3P

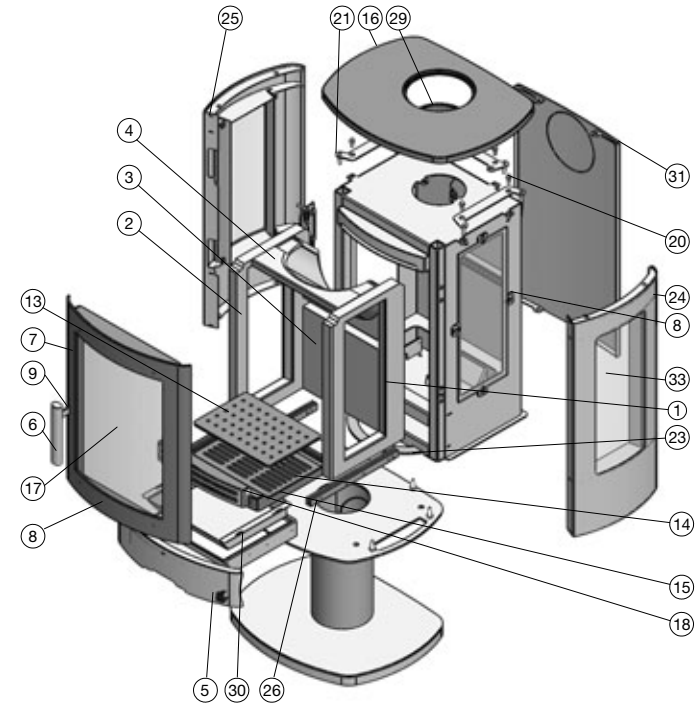

Diagram No.	Part No.	Description	Quantity Required
1	N41040001	Vermiculite right side brick	1
2	N41040002	Vermiculite left side brick	1
3	N41040003	Vermiculite rear brick	1
4	N41040004	Vermiculite baffle	1
5	N41033000	Sliding ash draw assembly	1
6	N41021000	Handle	1
7	N41020001	Cast iron door	1
8	N17015206	Glass clips	20
9	N41020002	Door handle bracket	1
N/A	N808-30-00	Door roller catch	2
N/A	N41041001	Inner blanking plate	1
N/A	N41041002	Ashpan lid	1
13	N41070003	Cast iron wood grate	1
14	N41070002	Cast iron solid fuel grate	1
15	N41070001	Cast iron grate support	1
16	N41060000	Cast iron top plate	1
17	N41045001	Front door glass	1
18	N41041015	Fuel retainer wood	1
N/A		Fuel retainer solid fuel	1
20	N41041014	Outer rear support bracket	1
21	N41041013	Outer side support brackets	2
N/A	N41041011	Baffle support bracket	1
23	N41041009	Control wheel	1
24	N41331000	Outer right panel	1
25	N41332000	Outer left panel	1
26		Ash draw runners	2
N/A		Door sealing gasket	1.7M
N/A		Glass sealing gasket	6.3M
28	N150-32	Cast iron collar	1
30	N41041002	Ashpan	1
31	N41237000	Outer Rear panel	1
32	N41045002	Inner side glass	2
33	N41045003	Outer side glass	2

Parts Information Neo 1W / 1F

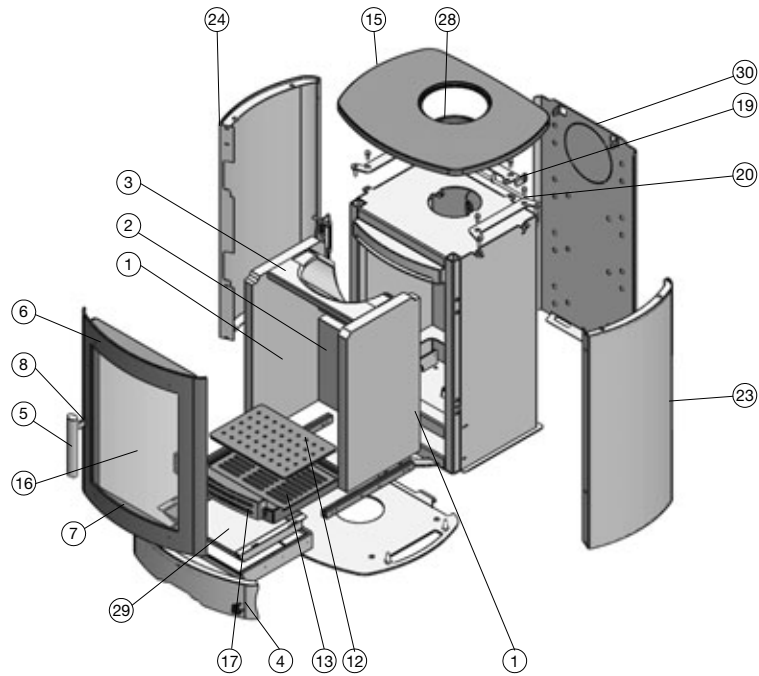

Diagram No.	Part No.	Description	Quantity Required
1	N4140002	Vermiculite side bricks	2
2	N41040003	Vermiculite rear brick	1
3	N41040004	Vermiculite baffle	1
4	N41033000	Sliding ash draw assembly	1
5	N41021000	Handle	1
6	N41020001	Cast iron door	1
7	N17015206	Glass clips	4
8	N41020002	Door handle bracket	1
N/A	N808-30-00	Door roller catch	2
N/A	N41041001	Inner blanking plate	1
N/A	N41041002	Ashpan lid	1
12	N41070003	Cast iron wood grate	1
13	N41070002	Cast iron solid fuel grate	1
14	N41070001	Cast iron grate support	1
15	N41060000	Cast iron top plate	1
16	N41045001	Front door glass	1
17	N41041015	Fuel retainer wood	1
N/A		Fuel retainer solid fuel	1
19	N41041014	Outer rear support bracket	1
20	N41041013	Outer side support brackets	2
N/A	N41041011	Baffle support bracket	1
22	N41041009	Control wheel	1
23	N41131000	Outer right panel	1
24	N41132000	Outer left panel	1
25		Ash draw runners	2
N/A		Door sealing gasket	1.7M
N/A		Glass sealing gasket	1.5M
28	N150-32	Cast iron collar	1
29	N41041002	Ashpan lid	1
30	N41435002	Outer Rear panel	1

Parts Information Neo 3W / 3F

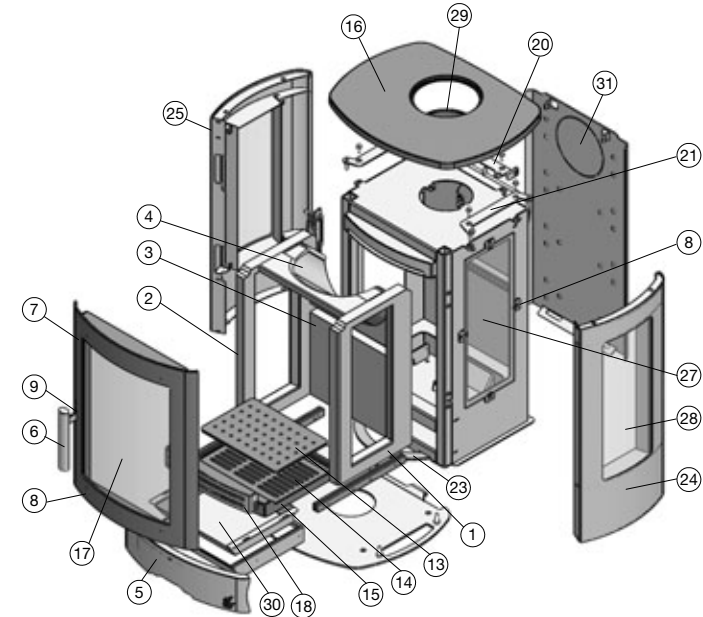

Diagram No.	Part No.	Description	Quantity Required
1	N41040001	Vermiculite right side brick	1
2	N41040002	Vermiculite left side brick	1
3	N41040003	Vermiculite rear brick	1
4	N41040004	Vermiculite baffle	1
5	N41033000	Sliding ash draw assembly	1
6	N41021000	Handle	1
7	N41020001	Cast iron door	1
8	N17015206	Glass clips	20
9	N41020002	Door handle bracket	1
N/A	N808-30-00	Door roller catch	2
N/A	N41041001	Inner blanking plate	1
N/A	N41041002	Ashpan lid	1
13	N41070003	Cast iron wood grate	1
14	N41070002	Cast iron solid fuel grate	1
15	N41070001	Cast iron grate support	1
16	N41060000	Cast iron top plate	1
17	N41045001	Front door glass	1
18	N41041015	Fuel retainer wood	1
N/A		Fuel retainer solid fuel	1
20	N41041014	Outer rear support bracket	1
21	N41041013	Outer side support brackets	2
N/A	N41041011	Baffle support bracket	1
23	N41041009	Control wheel	1
24	N41131000	Outer right panel	1
25	N41132000	Outer left panel	1
26		Ash draw runners	2
N/A		Door sealing gasket	1.7M
N/A		Glass sealing gasket	6.3M
27	N41045002	Inner side glass	2
28	N41045003	Outer side glass	2
29	N150-32	Cast iron collar	1
30	N41041002	Ashpan lid	1
31	N41435002	Outer Rear panel	1

Commissioning Check List

Please tick boxes when each procedure is completed

- Ensure the serial number has been recorded on the front of this manual for any future use
- Ensure the door seals are in good condition and that the glass is secured correctly in the door (do not over tighten the glass as this will prohibit its expansion and could cause the glass to crack)
- Ensure that all internal components are fitted correctly (these may have shifted in transit)
- Ensure that the appliance operates correctly during the first firing
- Ensure the customer is aware that fumes may be given off during the first firings as the paint cures
- Advise the customer on the safe operation of the appliance
- Leave the instruction manuals, operating tool and glove for the customer's use.
- Record the flue draught reading of the appliance

Warranty Information

The specifications within this document are provided for information purposes only and are under no circumstances binding.

With the aim of constantly improving our products, all modifications considered necessary may be made without notice.

This manual is correct at time of printing.

Our appliances are guaranteed against faults and hidden defects subject to the following conditions:

The appliance must have been installed by a registered competent installer (HETAS) or inspected by local authority Building Control.

The appliance must be installed and operated in accordance with our instruction manual.

The guarantee is for a period of 10 years on the appliance body from the date of purchase.

The following components are considered as consumables and are excluded from the guarantee:

- Grates
- Rope seals
- Ashpan
- Ashpan runners
- Internal vermiculite panels
- Glass
- Baffle plates

Your statutory rights are not affected by this warranty.



Warranty Claim Form

Customer Name:

Customer Address:

Daytime Tel: Mobile Tel:

Model Name: Model Number:

Serial Number: Date of purchase:

Date of installation:

Installer's Name and address:

Installer's Registration Number:

Building Control Certificate Number:
(if not installed by a registered competent installer)

Dealer Name and address:

In the unlikely event of a warranty claim, please return the above claim form to:

ACR Heat Products Limited, Unit 1, Weston Works,
Weston Lane, Tyseley, Birmingham, B11 3RP, England.

• Tel: 0121 706 8266

• Fax: 0121 706 9182

• E-mail: enquiries@acrheatproducts.co.uk

• www.acrheatproducts.co.uk



ACR
STOVES

ACR Heat Products Limited, Unit 1, Weston Works,
Weston Lane, Tyseley Birmingham B11 3RP, England.

- Tel: 0121 706 8266
- E-mail: enquiries@acrheatproducts.co.uk
- Fax: 0121 706 9182
- www.acrheatproducts.co.uk